

PHILIPPINE BIDDING DOCUMENTS

SUPPLY & DOOR-TO-DOOR DELIVERY OF SCHOOL FURNITURE FOR ELEMENTARY, JUNIOR AND SENIOR HIGH SCHOOLS UNDER BEFF CY 2023

PB ESSD 2023-004



**Department of Education
NATIONAL CAPITAL REGION**
Misamis Street, Bago Bantay, Quezon City
Email Address: procurement.ncr@deped.gov.ph



INVITATION TO BID FOR SUPPLY & DOOR-TO-DOOR DELIVERY OF SCHOOL FURNITURE FOR ELEMENTARY, JUNIOR AND SENIOR HIGH SCHOOLS UNDER BEFF CY 2023

1. The *Department of Education – National Capital Region (DepEd NCR)* intends to apply the sum of *ONE HUNDRED SIXTEEN MILLION NINE HUNDRED SIX THOUSAND TWO HUNDRED PESOS (PHP116,906,200.00)* being the ABC to payments under the contract for *Supply & Door-to-Door Delivery of School Furniture for Elementary, Junior and Senior High Schools under BEFF CY 2023/PB ESSD 2023-004*. Bids received in excess of the ABC per lot shall be automatically rejected at bid opening. The breakdown of the ABC per lot is indicated in the attached Terms of Reference (TOR).
2. The *DepEd – NCR* now invites bids for the above Procurement Project. Delivery of the Goods/Services required is *one hundred fifty (150) days from the receipt of the Notice to Proceed*. Bidders should have completed, within *three (3) years* from the date of submission and receipt of bids, a contract similar to the Project. The description of an eligible bidder is contained in the Bidding Documents, particularly, in Section II (Instructions to Bidders).
3. Bidding will be conducted through open competitive bidding procedures using a non-discretionary “*pass/fail*” criterion as specified in the 2016 revised Implementing Rules and Regulations (IRR) of Republic Act (RA) No. 9184.
 - a. Bidding is restricted to Filipino citizens/sole proprietorships, partnerships, cooperatives or organizations with at least sixty percent (60%) interest or outstanding capital stock belonging to citizens of the Philippines, and to citizens or organizations of a country the laws or regulations of which grant similar rights or privileges to Filipino citizens, pursuant to RA No. 5183.
4. Prospective Bidders may obtain further information from *DepEd - NCR* and inspect the Bidding Documents at the address given below during **8:00 AM to 5:00 PM**.
5. A complete set of Bidding Documents can be accessed at Agency’s website at <https://www.depedncr.com.ph/invitation-to-bid/> or may be acquired by interested Bidders starting **August 30, 2023** by requesting the PDF copy through the DepEd – NCR BAC Secretariat at email address: procurement.ncr@depd.gov.ph and upon payment of the applicable fee for the Bidding Documents, pursuant to the latest Guidelines issued by the GPPB, in the amount per lot indicated in the TOR.

The Prospective Bidders shall accomplish the bidder's information survey through this link <http://bit.ly/NCR-BiddersInformationSheet>. An Order of Payment shall be secured from the Procurement Unit for the payment of the Bidding Documents fee for the issuance of Official Receipt at the Cashier's Office of DepEd NCR.

6. The *DepEd – NCR* will hold a Pre-Bid Conference¹ on **September 13, 2023 – 2:00 PM** via Google Meet Platform, which shall be open to all prospective bidders. The meeting link will be sent to your email address upon notification.
7. Bids must be duly received by the BAC Secretariat both (i) manual submission at the office address indicated below, (ii) online or electronic submission at BAC email address: **bac.ncr@deped.gov.ph** on or before **9:00 AM of September 27, 2023**. Late bids shall not be accepted.
8. All Bids must be accompanied by a bid security in any of the acceptable forms and in the amount stated in **ITB** Clause 14.
9. Bid opening shall be on **September 27, 2023 – 10:00 AM** at DepEd – NCR Conference Hall and via **Google Meet Platform** for bidders' representatives who choose to attend the activity. Further instructions on the submission and opening of bids is stated in **ITB** Clause 16.
10. The *DepEd - NCR* reserves the right to reject any and all bids, declare a failure of bidding, or not award the contract at any time prior to contract award in accordance with Sections 35.6 and 41 of the 2016 revised IRR of RA No. 9184, without thereby incurring any liability to the affected bidder or bidders.
11. For further information, please refer to:

The BAC Secretariat/Procurement Unit
Misamis Street, Bago Bantay, Quezon City
Email Address: bac.ncr@deped.gov.ph or procurement.ncr@deped.gov.ph

August 24, 2023

CRISTITO A. ECO
BAC Chairperson

Section II. Instructions to Bidders

1. Scope of Bid

The Procuring Entity wishes to receive Bids for the *Supply & Door-to-Door Delivery of School Furniture for Elementary, Junior and Senior High Schools under BEFF CY 2023*, with identification number *PB ESSD 2023-004*.

The Procurement Project (referred to herein as “Project”) is composed of procurement of *School Furniture*, the details of which are described in Section VII (Technical Specifications).

2. Funding Information

2.1. *Government of the Philippines (GOP) General Appropriation Act (GAA) for CY 2023 in the amount of PHP116,906,200.00*

2.2. The source of funding is *GOP GAA CY 2023*.

3. Bidding Requirements

The Bidding for the Project shall be governed by all the provisions of RA No. 9184 and its 2016 revised IRR, including its Generic Procurement Manuals and associated policies, rules and regulations as the primary source thereof, while the herein clauses shall serve as the secondary source thereof.

Any amendments made to the IRR and other GPPB issuances shall be applicable only to the ongoing posting, advertisement, or **IB** by the BAC through the issuance of a supplemental or bid bulletin.

The Bidder, by the act of submitting its Bid, shall be deemed to have verified and accepted the general requirements of this Project, including other factors that may affect the cost, duration and execution or implementation of the contract, project, or work and examine all instructions, forms, terms, and project requirements in the Bidding Documents.

4. Corrupt, Fraudulent, Collusive, and Coercive Practices

The Procuring Entity, as well as the Bidders and Suppliers, shall observe the highest standard of ethics during the procurement and execution of the contract. They or through an agent shall not engage in corrupt, fraudulent, collusive, coercive, and obstructive practices defined under Annex “I” of the 2016 revised IRR of RA No. 9184 or other integrity violations in competing for the Project.

5. Eligible Bidders

5.1. Only Bids of Bidders found to be legally, technically, and financially capable will be evaluated.

5.2. Foreign ownership exceeding those allowed under the rules may participate pursuant to:

Citizens, corporations, or associations of a country, included in the list issued by the GPPB, the laws or regulations of which grant reciprocal rights or privileges to citizens, corporations, or associations of the Philippines;

5.3. Pursuant to Section 23.4.1.3 of the 2016 revised IRR of RA No.9184, the Bidder shall have an SLCC that is at least one (1) contract similar to the Project the value of which, adjusted to current prices using the PSA's CPI, must be at least equivalent to:

For the procurement of Non-expendable Supplies and Services: The Bidder must have completed a single contract that is similar to this Project, equivalent to at least fifty percent (50%) of the ABC.

5.4. The Bidders shall comply with the eligibility criteria under Section 23.4.1 of the 2016 IRR of RA No. 9184.

6. Origin of Goods

There is no restriction on the origin of goods other than those prohibited by a decision of the UN Security Council taken under Chapter VII of the Charter of the UN, subject to Domestic Preference requirements under **ITB** Clause 18.

7. Subcontracts

7.1. The Bidder may subcontract portions of the Project to the extent allowed by the Procuring Entity as stated herein, but in no case more than twenty percent (20%) of the Project.

The Procuring Entity has prescribed that: Subcontracting is not allowed.

8. Pre-Bid Conference

The Procuring Entity will hold a pre-bid conference for this Project on the specified date and time and either at its physical address *{insert if applicable}* and/or through videoconferencing/webcasting} as indicated in paragraph 6 of the **IB**.

9. Clarification and Amendment of Bidding Documents

Prospective bidders may request for clarification on and/or interpretation of any part of the Bidding Documents. Such requests must be in writing and received by the Procuring Entity, either at its given address or through electronic mail indicated in the **IB**, at least ten (10) calendar days before the deadline set for the submission and receipt of Bids.

10. Documents comprising the Bid: Eligibility and Technical Components in three (3) copies, original copy & copies 1 & 2

- 10.1. The first envelope shall contain the eligibility and technical documents of the Bid as specified in **Section VIII (Checklist of Technical and Financial Documents)**.
- 10.2. The Bidder's SLCC as indicated in **ITB** Clause 5.3 should have been completed within *three years* prior to the deadline for the submission and receipt of bids.
- 10.3. If the eligibility requirements or statements, the bids, and all other documents for submission to the BAC are in foreign language other than English, it must be accompanied by a translation in English, which shall be authenticated by the appropriate Philippine foreign service establishment, post, or the equivalent office having jurisdiction over the foreign bidder's affairs in the Philippines. Similar to the required authentication above, for Contracting Parties to the Apostille Convention, only the translated documents shall be authenticated through an apostille pursuant to GPPB Resolution No. 13-2019 dated 23 May 2019. The English translation shall govern, for purposes of interpretation of the bid.

11. Documents comprising the Bid: Financial Component in three (3) copies, original copy & copies 1 & 2

- 11.1. The second bid envelope shall contain the financial documents for the Bid as specified in **Section VIII (Checklist of Technical and Financial Documents)**.
- 11.2. If the Bidder claims preference as a Domestic Bidder or Domestic Entity, a certification issued by DTI shall be provided by the Bidder in accordance with Section 43.1.3 of the 2016 revised IRR of RA No. 9184.
- 11.3. Any bid exceeding the ABC indicated in paragraph 1 of the **IB** shall not be accepted.
- 11.4. For Foreign-funded Procurement, a ceiling may be applied to bid prices provided the conditions are met under Section 31.2 of the 2016 revised IRR of RA No. 9184.

12. Bid Prices

12.1. Prices indicated on the Price Schedule shall be entered separately in the following manner:

- a. For Goods offered from within the Procuring Entity's country:
 - i. The price of the Goods quoted EXW (ex-works, ex-factory, ex-warehouse, ex-showroom, or off-the-shelf, as applicable);
 - ii. The cost of all customs duties and sales and other taxes already paid or payable;
 - iii. The cost of transportation, insurance, and other costs incidental to delivery of the Goods to their final destination; and
 - iv. The price of other (incidental) services, if any, listed in the **BDS**.
- b. For Goods offered from abroad:
 - i. Unless otherwise stated in the **BDS**, the price of the Goods shall be quoted delivered duty paid (DDP) with the place of destination in the Philippines as specified in the **BDS**. In quoting the price, the Bidder shall be free to use transportation through carriers registered in any eligible country. Similarly, the Bidder may obtain insurance services from any eligible source country.
 - ii. The price of other (incidental) services, if any, as listed in the **BDS**.

13. Bid and Payment Currencies

13.1. For Goods that the Bidder will supply from outside the Philippines, the bid prices may be quoted in the local currency or tradeable currency accepted by the BSP at the discretion of the Bidder. However, for purposes of bid evaluation, Bids denominated in foreign currencies, shall be converted to Philippine currency based on the exchange rate as published in the BSP reference rate bulletin on the day of the bid opening.

13.2. Payment of the contract price shall be made in: Philippine Pesos.

14. Bid Security

14.1. The Bidder shall submit a Bid Securing Declaration² or any form of Bid Security in the amount indicated in the **BDS**, which shall be not less than the percentage of the ABC in accordance with the schedule in the **BDS**.

- 14.2. The Bid and bid security shall be valid until *120 calendar days*. Any Bid not accompanied by an acceptable bid security shall be rejected by the Procuring Entity as non-responsive.

15. Sealing and Marking of Bids

Each Bidder shall submit one copy of the first and second components of its Bid.

The Procuring Entity may request additional hard copies and/or electronic copies of the Bid. However, failure of the Bidders to comply with the said request shall not be a ground for disqualification.

If the Procuring Entity allows the submission of bids through online submission or any other electronic means, the Bidder shall submit an electronic copy of its Bid, which must be digitally signed. An electronic copy that cannot be opened or is corrupted shall be considered non-responsive and, thus, automatically disqualified.

16. Deadline for Submission of Bids

- 16.1. The Bidders shall submit on the specified date and time and either at its physical address or through online submission as indicated in paragraph 7 of the **IB**.
- a. Bids can be submitted electronically or manually or through mail courier or registered mail, the indicated date of receipt of the postal service or courier service shall be considered as date of submission to the BAC concerned, without prejudice to any verification during the post qualification.
 - b. Send hard copy via courier, on condition that the BAC Secretariat will be provided with the proof of waybill and the hard copies of the documents must be received by the BAC Secretariat before the actual opening of bids.
 - c. The electronic copies of the bids shall be sent to the BAC email address: **bac.ncr@deped.gov.ph** before the bid opening in PDF format and must be password-protected. The bidders must provide the password during the start of the documents scrutiny of the BAC members.
 - d. If the hard copies of the documents do not arrive as scheduled, the electronic copies of the documents will be appreciated by the members of the BAC, but during the post qualification, the original bidding documents will be opened and cross-validated. If there are inconsistencies of the data between the emailed copy and the original documents, the data reflected in the hard copy will prevail.
 - e. Any bid modification shall likewise be submitted electronically, provided that it is done before the deadline for submission and receipt of electronic bids. The actual time of electronic bid submission shall be the time reflected in the mail of the bidder.

17. Opening and Preliminary Examination of Bids

- 17.1. The BAC shall open the Bids in public at the time, on the date, and at the place specified in paragraph 9 of the **IB**. The Bidders' representatives who are present shall sign a register evidencing their attendance. In case videoconferencing, webcasting or other similar technologies will be used, attendance of participants shall likewise be recorded by the BAC Secretariat.

In case the Bids cannot be opened as scheduled due to justifiable reasons, the rescheduling requirements under Section 29 of the 2016 revised IRR of RA No. 9184 shall prevail.

- 17.2. The preliminary examination of bids shall be governed by Section 30 of the 2016 revised IRR of RA No. 9184.

18. Domestic Preference

- 18.1. The Procuring Entity will grant a margin of preference for the purpose of comparison of Bids in accordance with Section 43.1.2 of the 2016 revised IRR of RA No. 9184.

19. Detailed Evaluation and Comparison of Bids

- 19.1. The Procuring Entity's BAC shall immediately conduct a detailed evaluation of all Bids rated "*passed*," using non-discretionary pass/fail criteria. The BAC shall consider the conditions in the evaluation of Bids under Section 32.2 of the 2016 revised IRR of RA No. 9184.

- 19.2. If the Project allows partial bids, bidders may submit a proposal on any of the lots or items, and evaluation will be undertaken on a per lot or item basis, as the case maybe. In this case, the Bid Security as required by **ITB** Clause 14 shall be submitted for each lot or item separately.

- 19.3. The descriptions of the lots or items shall be indicated in **Section VII (Technical Specifications)**, although the ABCs of these lots or items are indicated in the **BDS** for purposes of the NFCC computation pursuant to Section 23.4.2.6 of the 2016 revised IRR of RA No. 9184. The NFCC must be sufficient for the total of the ABCs for all the lots or items participated in by the prospective Bidder.

- 19.4. The Project shall be awarded as follows:

Option 1 – One Project having several items that shall be awarded as one contract.

- 19.5. Except for bidders submitting a committed Line of Credit from a Universal or Commercial Bank in lieu of its NFCC computation, all Bids must include the NFCC computation pursuant to Section 23.4.1.4 of the 2016 revised IRR of RA No. 9184, which must be sufficient for the total of the ABCs for all the

lots or items participated in by the prospective Bidder. For bidders submitting the committed Line of Credit, it must be at least equal to ten percent (10%) of the ABCs for all the lots or items participated in by the prospective Bidder.

20. Post-Qualification

- 20.1. The BAC shall determine to its satisfaction whether the Bidder that is evaluated as having submitted the Lowest Calculated Bid complies with and is responsive to all the requirements and conditions.
- 20.2. Within a non-extendible period of five (5) calendar days from receipt by the bidder of the notice from the BAC that it submitted the Lowest Calculated Bid, the Bidder shall submit its latest income and business tax returns filed and paid through the BIR Electronic Filing and Payment System (eFPS) and other appropriate licenses and permits required by law and stated in the [BDS](#).
- 20.3. Failure to submit any of the post-qualification requirements on time, or a finding against the veracity thereof, shall disqualify the bidder for award. Provided in the event that a finding against the veracity of any of the documents submitted is made, it shall cause the forfeiture of the bid security in accordance with Section 69 of the IRR of RA 9184.
- 20.4. The determination shall be based upon an examination of the documentary evidence of the Bidder's qualifications as well as other information as the Procuring Entity deems necessary and appropriate, using a non-discretionary "pass/fail" criterion, which shall be completed within a period of twelve (12) calendar days.
- 20.5. If the BAC determines that the Bidder with the Lowest Calculated Bid passes all the criteria for post-qualification, it shall declare the said bid as the LCRB, and recommend to the HoPE the award of contract to the said Bidder at its submitted price or its calculated bid price, whichever is lower.
- 20.6. A negative determination shall result in rejection of the Bidder's Bid, in which event the Procuring Entity shall proceed to the next Lowest Calculated Bid with a fresh period to make a similar determination of that Bidder's capabilities to perform satisfactorily. If the second Bidder, however, fails the post qualification, the procedure for post qualification shall be repeated for the Bidder with the next Lowest Calculated Bid, and so on until the LCRB is determined for recommendation for contract award.
- 20.7. Within a period not exceeding fifteen (15) calendar days from the determination by the BAC of the LCRB and the recommendation to award the contract, the HoPE or his duly authorized representative shall approve or disapprove the said recommendation.
- 20.8. In the event of disapproval, which shall be based on valid, reasonable, and justifiable grounds as provided for under Section 41 of the IRR of RA 9184, the HoPE shall notify the BAC and the Bidder in writing of such decision and the grounds for it. When applicable, the BAC shall conduct a post-qualification of the Bidder with the next Lowest Calculated Bid. A request for

reconsideration may be filed by the bidder with the HoPE in accordance with Section 37.1.3 of the IRR of RA 9184.

21 Signing of the Contract

- 21.1. The documents required in Section 37.2 of the 2016 revised IRR of RA No. 9184 shall form part of the Contract. Additional Contract documents are indicated in the **BDS**.

Section III. Bid Data Sheet

| ITB Clause | |
|---------------|---|
| 5.3 | <p>For this purpose, contracts similar to the Project shall be:</p> <ul style="list-style-type: none"> a. Similar contracts pertain to contract for the <i>school furniture projects</i> b. Completed prior to the deadline for the submission and receipt of bids. |
| 12 | The price of the Goods shall be quoted DDP [<i>state place of destination</i>] or the applicable International Commercial Terms (INCOTERMS) for this Project. |
| 14.1 | <p>The bid security shall be in the form of, or any of the following forms and amounts:</p> <ul style="list-style-type: none"> a. A notarized Bid Securing Declaration (BSD) or b. The amount of not less than the <i>equivalent to two percent (2%) of ABC per lot</i>, if bid security is in cash, cashier's/manager's check, bank draft/guarantee or irrevocable letter of credit; or c. The amount of not less than <i>equivalent to five percent (5%) of ABC per lot</i> if bid security is in Surety Bond. |

Section IV. General Conditions of Contract

1. Scope of Contract

This Contract shall include all such items, although not specifically mentioned, that can be reasonably inferred as being required for its completion as if such items were expressly mentioned herein. All the provisions of RA No. 9184 and its 2016 revised IRR, including the Generic Procurement Manual, and associated issuance, constitute the primary source for the terms and conditions of the Contract, and thus, applicable in contract implementation. Herein clauses shall serve as the secondary source for the terms and conditions of the Contract.

This is without prejudice to Sections 74.1 and 74.2 of the 2016 revised IRR of RA No. 9184 allowing the GPPB to amend the IRR, which shall be applied to all procurement activities, the advertisement, posting, or invitation of which were issued after the effectivity of the said amendment.

Additional requirements for the completion of this Contract shall be provided in the **Special Conditions of Contract (SCC)**.

2. Advance Payment and Terms of Payment

2.1. Advance payment of the contract amount is provided under Annex "D" of the revised 2016 IRR of RA No. 9184.

2.2. The Procuring Entity is allowed to determine the terms of payment on the partial or staggered delivery of the Goods procured, provided such partial payment shall correspond to the value of the goods delivered and accepted in accordance with prevailing accounting and auditing rules and regulations. The terms of payment are indicated in the **SCC**.

3. Performance Security

Within ten (10) calendar days from receipt of the Notice of Award by the Bidder from the Procuring Entity but in no case later than the signing of the Contract by both parties, the successful Bidder shall furnish the performance security in any of the forms prescribed in Section 39 of the 2016 revised IRR of RA No. 9184.

4. Inspection and Tests

The Procuring Entity or its representative shall have the right to inspect and/or to test the Goods to confirm their conformity to the Project specifications at no extra cost to the Procuring Entity in accordance with the Generic Procurement Manual. In addition to tests in the **SCC**, **Section VII (Technical Specifications)** shall specify what inspections and/or tests the Procuring Entity requires, and where they are to be conducted. The Procuring Entity shall notify the Supplier in writing, in a timely manner, of the identity of any representatives retained for these purposes.

All reasonable facilities and assistance for the inspection and testing of Goods, including access to drawings and production data, shall be provided by the Supplier to the authorized inspectors at no charge to the Procuring Entity.

5. Warranty

- 5.1 In order to assure that manufacturing defects shall be corrected by the Supplier, a warranty shall be required from the Supplier as provided under Section 62.1 of the 2016 revised IRR of RA No. 9184.
- 5.2 The Procuring Entity shall promptly notify the Supplier in writing of any claims arising under this warranty. Upon receipt of such notice, the Supplier shall, repair or replace the defective Goods or parts thereof without cost to the Procuring Entity, pursuant to the Generic Procurement Manual.

6. Liability of the Supplier

The Supplier's liability under this Contract shall be as provided by the laws of the Republic of the Philippines.

If the Supplier is a joint venture, all partners to the joint venture shall be jointly and severally liable to the Procuring Entity

Section V. Special Conditions of Contract

| GCC Clause | |
|------------|--|
| 1 | <p>Delivery and Documents –</p> <p>For purposes of the Contract, “EXW,” “FOB,” “FCA,” “CIF,” “CIP,” “DDP” and other trade terms used to describe the obligations of the parties shall have the meanings assigned to them by the current edition of INCOTERMS published by the International Chamber of Commerce, Paris. The Delivery terms of this Contract shall be as follows:</p> <p><i>The delivery site is the various schools of DepEd NCR. The delivery period is 180 calendar days.</i></p> <p>“The delivery terms applicable to this Contract are delivered to DepEd NCR. Risk and title will pass from the Supplier to the Procuring Entity upon receipt and final acceptance of the Goods at their final destination.”</p> <p>Delivery of the Goods shall be made by the Supplier in accordance with the terms specified in Section VI (Schedule of Requirements).</p> <p>For purposes of this Clause the Procuring Entity’s Representative at the Project Site is <i>ESSD of DepEd NCR</i>.</p> <p>Incidental Services –</p> <p>The Supplier is required to provide all of the following services, including additional services, if any, specified in Section VI. Schedule of Requirements:</p> <p><i>Select appropriate requirements and delete the rest.</i></p> <ol style="list-style-type: none"> a. performance or supervision of on-site assembly and/or start-up of the supplied Goods; b. furnishing of tools required for assembly and/or maintenance of the supplied Goods; c. furnishing of a detailed operations and maintenance manual for each appropriate unit of the supplied Goods; d. performance or supervision or maintenance and/or repair of the supplied Goods, for a period of time agreed by the parties, provided that this service shall not relieve the Supplier of any warranty obligations under this Contract; and |
| | <ol style="list-style-type: none"> e. training of the Procuring Entity’s personnel, at the Supplier’s plant and/or on-site, in assembly, start-up, operation, maintenance, and/or repair of the supplied Goods. |

f. *[Specify additional incidental service requirements, as needed.]*

The Contract price for the Goods shall include the prices charged by the Supplier for incidental services and shall not exceed the prevailing rates charged to other parties by the Supplier for similar services.

Spare Parts –

The Supplier is required to provide all of the following materials, notifications, and information pertaining to spare parts manufactured or distributed by the Supplier:

Select appropriate requirements and delete the rest.

1. such spare parts as the Procuring Entity may elect to purchase from the Supplier, provided that this election shall not relieve the Supplier of any warranty obligations under this Contract; and
2. in the event of termination of production of the spare parts:
 - i. advance notification to the Procuring Entity of the pending termination, in sufficient time to permit the Procuring Entity to procure needed requirements; and
 - ii. following such termination, furnishing at no cost to the Procuring Entity, the blueprints, drawings, and specifications of the spare parts, if requested.

The spare parts and other components required are listed in **Section VI (Schedule of Requirements)** and the costs thereof are included in the contract price.

The Supplier shall carry sufficient inventories to assure ex-stock supply of consumable spare parts or components for the Goods for a period of *[indicate here the time period specified. If not used indicate a time period of three times the warranty period]*.

Spare parts or components shall be supplied as promptly as possible, but in any case, within *[insert appropriate time period]* months of placing the order.

Packaging –

The Supplier shall provide such packaging of the Goods as is required to prevent their damage or deterioration during transit to their final destination, as indicated in this Contract. The packaging shall be sufficient to withstand, without limitation, rough handling during transit and exposure to extreme temperatures, salt and precipitation during transit, and open storage. Packaging case size and weights shall take into consideration, where appropriate, the remoteness of the

| | |
|--|--|
| | <p>Goods' final destination and the absence of heavy handling facilities at all points in transit.</p> <p>The packaging, marking, and documentation within and outside the packages shall comply strictly with such special requirements as shall be expressly provided for in the Contract, including additional requirements, if any, specified below, and in any subsequent instructions ordered by the Procuring Entity.</p> <p>The outer packaging must be clearly marked on at least four (4) sides as follows:</p> <p>Name of the Procuring Entity : <i>DepEd - NCR</i> Name of the Supplier : Contract Description : <i>Supply and Door-to-Door Delivery of Elementary, Junior and Senior High Schools under BEFF CY 2023</i> Final Destination : <i>Various Schools of DepEd NCR</i> Gross weight Any special lifting instructions Any special handling instructions Any relevant HAZCHEM classifications</p> |
| | <p>A packaging list identifying the contents and quantities of the package is to be placed on an accessible point of the outer packaging if practical. If not practical the packaging list is to be placed inside the outer packaging but outside the secondary packaging.</p> <p>Transportation –</p> <p>Where the Supplier is required under Contract to deliver the Goods CIF, CIP, or DDP, transport of the Goods to the port of destination or such other named place of destination in the Philippines, as shall be specified in this Contract, shall be arranged and paid for by the Supplier, and the cost thereof shall be included in the Contract Price.</p> <p>Where the Supplier is required under this Contract to transport the Goods to a specified place of destination within the Philippines, defined as the Project Site, transport to such place of destination in the Philippines, including insurance and storage, as shall be specified in this Contract, shall be arranged by the Supplier, and related costs shall be included in the contract price.</p> |

| | |
|-----|---|
| | <p>Where the Supplier is required under Contract to deliver the Goods CIF, CIP or DDP, Goods are to be transported on carriers of Philippine registry. In the event that no carrier of Philippine registry is available, Goods may be shipped by a carrier which is not of Philippine registry provided that the Supplier obtains and presents to the Procuring Entity certification to this effect from the nearest Philippine consulate to the port of dispatch. In the event that carriers of Philippine registry are available but their schedule delays the Supplier in its performance of this Contract the period from when the Goods were first ready for shipment and the actual date of shipment the period of delay will be considered force majeure.</p> <p>The Procuring Entity accepts no liability for the damage of Goods during transit other than those prescribed by INCOTERMS for DDP deliveries. In the case of Goods supplied from within the Philippines or supplied by domestic Suppliers risk and title will not be deemed to have passed to the Procuring Entity until their receipt and final acceptance at the final destination.</p> <p>Intellectual Property Rights –</p> <p>The Supplier shall indemnify the Procuring Entity against all third-party claims of infringement of patent, trademark, or industrial design rights arising from use of the Goods or any part thereof.</p> |
| 2.2 | <p><i>[If partial payment is allowed, state]</i> “The terms of payment shall be as follows: _____.”</p> |
| 4 | <p>The inspections and tests that will be conducted are: <i>[Indicate the applicable inspections and tests]</i></p> |

Section VI. Schedule of Requirements

The delivery schedule expressed as weeks/months stipulates hereafter a delivery date which is the date of delivery to the project site.

| Item Number | Description | Quantity Intended per Lot | | Total | Delivered, Weeks/Months |
|--------------------|--|----------------------------------|--|--------------|--------------------------------|
| 1 | Elem. Individual Learner Table & Chair Set | | | | |
| 2 | JHS Individual Learner Table & Chair Set | | | | |
| 3 | SHS Individual Learner Table & Chair Set | | | | |
| 4 | Teacher's Table & Chair Set | | | | |

Section VII. Technical Specifications

| Item | Specification | Statement of Compliance |
|------|---|--|
| | | <i>[Bidders must state here either "Comply" or "Not Comply" against each of the individual parameters of each Specification stating the corresponding performance parameter of the equipment offered. Statements of "Comply" or "Not Comply" must be supported by evidence in a Bidders Bid and cross-referenced to that evidence. Evidence shall be in the form of manufacturer's un-amended sales literature, unconditional statements of specification and compliance issued by the manufacturer, samples, independent test data etc., as appropriate. A statement that is not supported by evidence or is subsequently found to be contradicted by the evidence presented will render the Bid under evaluation liable for rejection. A statement either in the Bidder's statement of compliance or the supporting evidence that is found to be false either during Bid evaluation, post-qualification or the execution of the Contract may be regarded as fraudulent and render the Bidder or supplier liable for prosecution subject to the applicable laws and issuances.]</i> |
| | Please refer to the attached detailed Technical Specifications/Drawings. | |
| 1 | ES/JHS/SHS Individual Learner Table & Chair Individual Learner Table & Chair shall be the type of school furniture to be manufactured for the use of elementary and high school learners | |
| 2 | Teacher's Table & Chair shall be manufactured for the use of the teachers | |
| | The plans and technical specifications of the individual learners table and chair and teacher's table and chair shall follow the attached design and Technical Specifications found in its Annex. Suppliers/manufacturer must comply with the detailed technical specifications of learners table and chair and teacher's table and chair. | |

Section VIII. Checklist of Technical and Financial Documents

I. TECHNICAL COMPONENT ENVELOPE

Class “A” Documents

Legal Documents

- (a) Valid/Updated PhilGEPS Registration Certificate (Platinum Membership) (all pages);
including the following as supporting documents:
- (b) Registration certificate from Securities and Exchange Commission (SEC), Department of Trade and Industry (DTI) for sole proprietorship, or Cooperative Development Authority (CDA) for cooperatives or its equivalent document,
and
- (c) Mayor’s or Business permit issued by the city or municipality where the principal place of business of the prospective bidder is located, or the equivalent document for Exclusive Economic Zones or Areas;
and
- (d) Tax clearance per E.O. No. 398, s. 2005, as finally reviewed and approved by the Bureau of Internal Revenue (BIR).

Technical Documents

- (e) Statement of the prospective bidder of all its ongoing government and private contracts, including contracts awarded but not yet started, if any, whether similar or not similar in nature and complexity to the contract to be bid; **and**
- (f) Statement of the bidder’s Single Largest Completed Contract (SLCC) similar to the contract to be bid, except under conditions provided for in Sections 23.4.1.3 and 23.4.2.4 of the 2016 revised IRR of RA No. 9184, within the relevant period as provided in the Bidding Documents supported by NOA, NTP, Contract/Job Order and Certificate of Completion or Acceptance; **and**
- (g) Original copy of Bid Security. If in the form of a Surety Bond, submit also a certification issued by the Insurance Commission;
or
Original copy of Notarized Bid Securing Declaration; **and**
- (h) Conformity with the Technical Specifications, which may include production/delivery schedule, manpower requirements, and/or after-sales/parts, if applicable; **and**
- (i) Original duly signed Omnibus Sworn Statement (OSS);
and if applicable, Original Notarized Secretary’s Certificate in case of a corporation, partnership, or cooperative; or Original Special Power of Attorney of all members of the joint venture giving full power and authority to its officer to sign the OSS and do acts to represent the Bidder.

Financial Documents

- (j) The Supplier’s audited financial statements, showing, among others, the Supplier’s total and current assets and liabilities, stamped “received” by the

BIR or its duly accredited and authorized institutions, for the preceding calendar year which should not be earlier than two (2) years from the date of bid submission; **and**

- (k) The prospective bidder's computation of Net Financial Contracting Capacity (NFCC). $NFCC = [(Current\ Asset\ minus\ Current\ Liabilities) \times K]$ minus the value of all outstanding projects under on-going contracts, including awarded contracts;

Where K is 15

or

A committed Line of Credit from a Universal or Commercial Bank in lieu of its NFCC computation.

Class "B" Documents

- (l) If applicable, a duly signed joint venture agreement (JVA) in case the joint venture is already in existence;
and
duly notarized statements from all the potential joint venture partners stating that they will enter into and abide by the provisions of the JVA in the instance that the bid is successful.

II. FINANCIAL COMPONENT ENVELOPE

- (m) Original of duly signed and accomplished Financial Bid Form; **and**
- (n) Original of duly signed and accomplished Price Schedule(s).

Other documentary requirements under RA No. 9184 (as applicable)

- (o) [For foreign bidders claiming by reason of their country's extension of reciprocal rights to Filipinos] Certification from the relevant government office of their country stating that Filipinos are allowed to participate in government procurement activities for the same item or product.
- (p) Certification from the DTI if the Bidder claims preference as a Domestic Bidder or Domestic Entity.

Prospective bidders are advised to utilize forms downloaded from the GPPB website at <https://www.gppb.gov.ph/downloadables.php>.

Republic of the Philippines



Government Procurement Policy Board

TERMS OF REFERENCE

PROJECT TITLE: **SUPPLY & DOOR-TO-DOOR DELIVERY OF SCHOOL FURNITURE FOR ELEMENTARY, JUNIOR AND SENIOR HIGH SCHOOLS UNDER THE BASIC EDUCATION FACILITIES FUNDS (BEFF) SCHOOLS FURNITURE PROGRAM CY 2023**

OBJECTIVE: To provide school furniture to selected Public Elementary, Junior and Senior High Schools in the National Capital Region (NCR)

DEFINITION OR TERM:

Door-to-door delivery means to deliver school furniture inside the classroom and arrange accordingly in the intended room.

I. APPROVED BUDGET FOR THE CONTRACT (ABC) IN NCR FOR REGULAR SUPPLIERS:

| <i>Division</i> | <i>No. of Sites</i> | <i>Elem. Individual Learner Table & Chair Set</i> | <i>JHS Individual Learner Table & Chair Set</i> | <i>SHS Individual Learner Table & Chair Set</i> | <i>Teacher's Table & Chair Set</i> | <i>ABC (Php)</i> |
|-----------------------|---------------------|---|---|---|--|-----------------------|
| Caloocan City | 10 | 3,240 | 1,430 | 0 | 104 | 15,028,200.00 |
| City of San Juan | 1 | 0 | 1,080 | 0 | 24 | 3,475,200.00 |
| Las Piñas City | 5 | 900 | 360 | 1,560 | 68 | 9,102,400.00 |
| Malabon City | 2 | 360 | 360 | 0 | 16 | 2,316,800.00 |
| Mandaluyong City | 1 | 540 | 0 | 0 | 12 | 1,737,600.00 |
| Manila | 15 | 9,990 | 2,520 | 480 | 290 | 41,806,000.00 |
| Marikina City | 1 | 0 | 360 | 0 | 8 | 1,158,400.00 |
| Muntinlupa City | 2 | 720 | 0 | 0 | 16 | 2,316,800.00 |
| Navotas City | 10 | 3,240 | 1,080 | 0 | 96 | 13,900,800.00 |
| Paranaque City | 1 | 360 | 0 | 0 | 8 | 1,158,400.00 |
| Quezon City | 3 | 900 | 360 | 0 | 28 | 4,054,400.00 |
| Taguig City & Pateros | 7 | 2,340 | 1,800 | 0 | 92 | 13,321,600.00 |
| Valenzuela City | 3 | 2,340 | 0 | 0 | 52 | 7,529,600.00 |
| TOTAL | 61 | 24,930 | 9,350 | 2,040 | 814 | 116,906,200.00 |

a. ABC per Lot

| <i>Lot</i> | <i>Division</i> | <i>No. of Sites</i> | <i>Elem. Individual Learner Table & Chair Set</i> | <i>JHS Individual Learner Table & Chair Set</i> | <i>SHS Individual Learner Table & Chair Set</i> | <i>Teacher's Table & Chair Set</i> | <i>ABC (Php)</i> |
|------------|-------------------------|---------------------|---|---|---|--|-----------------------|
| 1 | Cal – CD I | 5 | 1,800 | 800 | 0 | 58 | 8,367,400.00 |
| 2 | Cal – CD II | 5 | 1,440 | 630 | 0 | 46 | 6,660,800.00 |
| 3 | SJ, Mand, Mrkn & QC | 6 | 1,440 | 1,800 | 0 | 72 | 10,425,600.00 |
| 4 | LP, Munt & P'que | 8 | 1,980 | 360 | 1,560 | 92 | 12,577,600.00 |
| 5 | Mal & Val | 5 | 2,700 | 360 | 0 | 68 | 9,846,400.00 |
| 6 | Manila - CD I & VI | 3 | 3,240 | 0 | 0 | 72 | 10,425,600.00 |
| 7 | Manila - CD II | 5 | 1,440 | 2,520 | 480 | 100 | 14,294,000.00 |
| 8 | Manila - CD III, IV & V | 7 | 5,310 | 0 | 0 | 118 | 17,086,400.00 |
| 9 | Navotas | 10 | 3,240 | 1,080 | 0 | 96 | 13,900,800.00 |
| 10 | TaPat | 7 | 2,340 | 1,800 | 0 | 92 | 13,321,600.00 |
| | Total | 61 | 24,930 | 9,350 | 2,040 | 814 | 116,906,200.00 |

b. Bidding Documents' Fee per Lot

| Lot | ABC (Php) | Bidding Documents' Fee (Php) |
|------------|------------------|-------------------------------------|
| 1 | 8,367,400.00 | 10,000.00 |
| 2 | 6,660,800.00 | 10,000.00 |
| 3 | 10,425,600.00 | 25,000.00 |
| 4 | 12,577,600.00 | 25,000.00 |
| 5 | 9,846,400.00 | 10,000.00 |
| 6 | 10,425,600.00 | 25,000.00 |
| 7 | 14,294,000.00 | 25,000.00 |
| 8 | 17,086,400.00 | 25,000.00 |
| 9 | 13,900,800.00 | 25,000.00 |
| 10 | 13,321,600.00 | 25,000.00 |

II. DESIGNS AND TECHNICAL SPECIFICATIONS

- a. Individual Learner's Table and Chair shall be the type of school furniture to be manufactured for the use of elementary and high school learners.
- b. Teacher's Table and Chair shall be manufactured for the use of the teachers.
- c. The plans and technical specifications of the individual learner's table and chair and teacher's table and chair shall follow the attached Design and Technical Specifications.
- d. Suppliers/Manufacturer must comply with the detailed technical specifications of learner's table and chair and teacher's table and chair.

III. SCHEDULE OF REQUIREMENTS

The Schedule of Requirements for the Supply and Door to Door Delivery of the school furniture for each package shall be referred to Section VI of the Bidding Documents.

IV. DELIVERY OF SCHOOL FURNITURE

- a. The school furniture shall be **delivered door-to-door**. The supplier shall be responsible for the transport of the school furniture from the manufacturer's plant up to the recipient schools.
- b. All materials used in the school furniture to be delivered to the school shall be **free** from defects, poor finish or poor paint job, presence of termites or any wood bearing insects, poor assembly, untreated wood, substandard material, imperfection and other analogous defects for the use of the learners.
- c. Only school furniture with the best quality and workmanship shall be acceptable to DepEd NCR.
- d. All school furniture found to be with defects, imperfections and poor quality and poor workmanship shall be rejected by DepEd NCR at any stage of the contract implementation.

- f. Delivery shall be during Office hours (8:00 AM to 5:00 PM). The supplier shall refrain from delivering goods on Saturday, Sunday and Holiday.
- g. Delivered school furniture at site shall be inspected by the School Inspectorate Team and accepted by the School Property Custodian.
- h. The Delivery Receipt (DR) shall be signed by the School Property Custodian.

V. CONTRACT DURATION

- a. All deliverables shall be complied within the Contract Duration.
- b. The Contract Period shall start three (3) calendar days upon receipt of the NTP.
- c. The required Delivery Period for the school furniture of DepEd NCR is one hundred fifty (150) calendar days.

VI. TERMS OF PAYMENT

- a. Progress payment shall be allowed to the Supplier upon accomplishment/delivery of at least 25% of the requirement of the Contract.
- b. Final payment shall be effected upon 100% delivery of all the requirements.
- c. Three percent (3%) retention money shall be deducted for every progress payment.

VII. LIQUIDATED DAMAGES

- a. When the Supplier fails to satisfactorily deliver goods under the Contract within the specified delivery schedule, inclusive of duly granted time extensions, if any. The Supplier shall be liable for damages for the delay and shall pay the procuring entity liquidated damages.
- b. An amount equal to one-tenth (1/10) of one percent (1%) of the cost of the delayed goods scheduled for delivery for every day of delay until such goods are finally delivered and accepted by the Procuring Entity.
- c. Such amount shall be deducted from any money due or which may become due to the Supplier, or collected from any securities or warranties posted by the Supplier whichever is convenient to the Procuring Entity concerned.
- d. In case the total sum of liquidated damages reaches ten percent (10%) of the total Contract Price, the Procuring Entity concerned may rescind the Contract and impose appropriate sanctions over and above the liquidated damages to be paid.

VIII. IMPLEMENTATION

Annex D of the 2016 Revised Implementing Rules and Regulations of Republic Act No. 9184 "Contract Implementation Guidelines in the Procurement of Goods, Supplies and Materials" shall be the guide in the Contract implementation of the Supply and Door-to-Door Delivery of

School Furniture to Elementary, Junior and Senior High Schools under the CY 2023 BEFF School Furniture Program.

IX. WARRANTY

- a. The Supplier shall supply and deliver only the best furniture for the learners and teachers.
- b. The Supplier warrants that any damage or defect in the goods delivered, the Supplier shall automatically and immediately replace the same with no question at no cost to the school, DepEd NCR within two weeks from the time of the defects become apparent and reported by the school.
- c. The Supplier shall replace or immediately compensate the school for replacement of damaged goods, unassembled furniture, or any other defects attributable to the delivery and factory defect of the items delivered within two years from delivery, except for damages caused while being used by the learners in the school.
- d. Supplier must immediately replace defective furniture and deliver its replacement without any cost with one week from the reported presence of defects. Supplier cannot deny or refuse the immediate replacement of the reported patently defective goods delivered to the school reasoning the goods were accepted by the school who are not experts to determine the quality of the goods delivered.
- e. Failure to do so, will be a valid ground to terminate the contract for default and cause the blacklisting of the Supplier from participating in any government Contracts for a period of five (5) years.

| 1 | TECHNICAL SPECIFICATIONS OF LEARNER'S TABLE | |
|------|---|---|
| MARK | COMPONENTS | SPECIFICATIONS |
| A | TABLE TOP | 18MM THK TOP BOARD ROUND CORNER'S (1 SIDE 1.0MM THK HIGH PRESSURE LAMINATE/1 SIDE VARNISH FINISHES ON MARINE PLYWOOD) |
| B | EDGING | 1.0 MM THK PVC EDGING, ALL EDGES OF TABLE TOP |
| C | SHELF | METAL WIRE MESH 4MMTHKX50X50 |
| D | FRONT COVER | 6MM THK FRONT COVER (1 SIDE 1.0MM THK HIGH PRESSURE LAMINATE / 1 SIDE VARNISH FINISHES ON MARINE PLYWOOD) |
| E | MAIN FRAME | 1.0MMTHKX20MMX40MM STEEL TUBULAR |
| F | SECONDARY FRAME | 1.0MMTHKX20MMX20MM STEEL TUBULAR |
| G | ADJUSTABLE LEVELER | 8MMØ THREAD WITH 38MMØ PLASTIC BASE |
| | CONNECTOR/FLAT BAR | 1MMTHKX25MMX50MM STEEL FLAT BAR (TABLE TOP: 4PCS; SCREW) |
| | CONNECTION | WOOD TO STEEL: SCREW: E-TYPE HEX M6X13mm: (TABLE TOP) RIVETS: BLIND RIVET (FRONT COVER) STEEL TO STEEL: FULL WELDING CONNECTION |

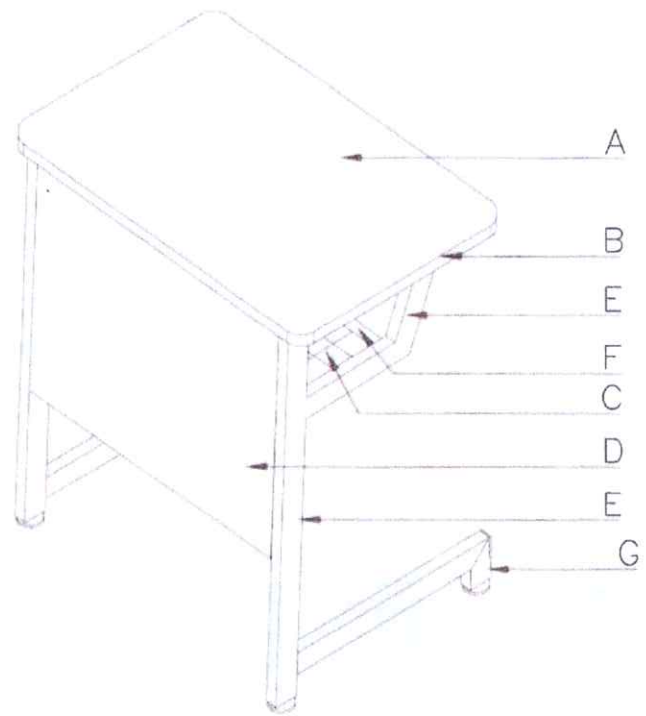

1 ISOMETRIC VIEW OF LEARNER'S TABLE
1 SCALE -M

| | | |
|---------------------|--|--|
| 2a | SCHEDULE OF FINISHES | |
| TOP BOARD | 1.0MM THK HIGH PRESSURE LAMINATE | |
| EDGING | 1.0 MM THK PVC EDGING, ALL EDGES OF TABLE TOP | |
| FRONT COVER | 1.0MM THK HIGH PRESSURE LAMINATE | |
| METAL/STEEL TUBULAR | POWDER COATED (BLACK); SMOOTH, GLOSSY FINISH | |
| LAMINATE COLOR | PANTONE 729C OR COLOR HEX #b07c45 / RGB 186, 124, 69 / CMYK 0%, 33%, 63%, 27% WITH WOOD GRAIN (SERANO BEECH OR EQUIVALENT) | |

| 3 | DIMENSIONS OF LEARNER'S TABLE(mm) (TOLERANCE ± 10mm) | | |
|------|---|------------|-----------|
| MARK | COMPONENTS | DIMENSIONS | |
| | | ELEMENTARY | SECONDARY |
| a | TABLE HEIGHT | 670 | 730 |
| b | TABLE LENGTH | 600 | 600 |
| c | TABLE WIDTH | 400 | 400 |

| | | | | | | | |
|---|--|--|---|---|---|--|--|
| REPUBLIC OF THE PHILIPPINES DepEd DEPARTMENT OF EDUCATION EDUCATION FACILITIES DIVISION MERRILL ROAD ALABANG, PASIG CITY | DRAWN BY: RA. RAYMOND G. ALARCON ARCHITECT | RECOMMENDING APPROVAL: ENGR. ANNABELLE E. PANGAN CHIEF - CARON FACILITIES DIVISION | APPROVED BY: EPIMACO V. ARSENO II Undersecretary for School Infrastructure and Facilities | CONCURRED BY: GINA O. GORING Undersecretary for Curriculum and Teaching | PROJECT TITLE: LEARNER'S TABLE (WOOD & STEEL) | SHEET CONTENTS: TECHNICAL SPECIFICATION SCHEDULE OF FINISHES EDGING APPLICATION DIMENSIONS ISOMETRIC VIEW | SHEET NO: <div style="border: 1px solid black; border-radius: 50%; width: 30px; height: 30px; display: flex; align-items: center; justify-content: center;"> <div style="border: 1px solid black; border-radius: 50%; width: 15px; height: 15px; display: flex; align-items: center; justify-content: center;">1</div> <div style="border: 1px solid black; border-radius: 50%; width: 15px; height: 15px; display: flex; align-items: center; justify-content: center;">3</div> </div> |
|---|--|--|---|---|---|--|--|

DEPED ELEMENTARY SINGLE LEARNER'S TABLE

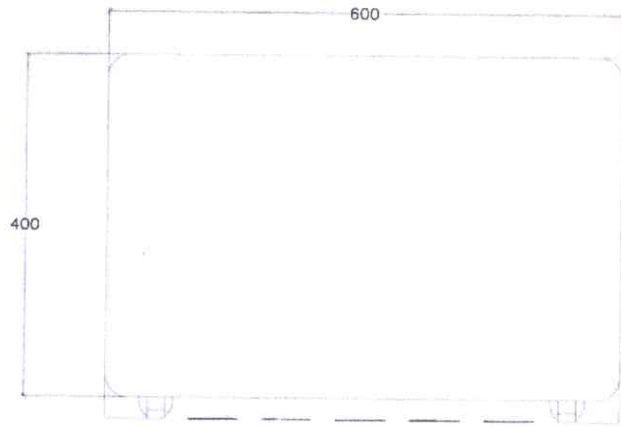

TOP VIEW

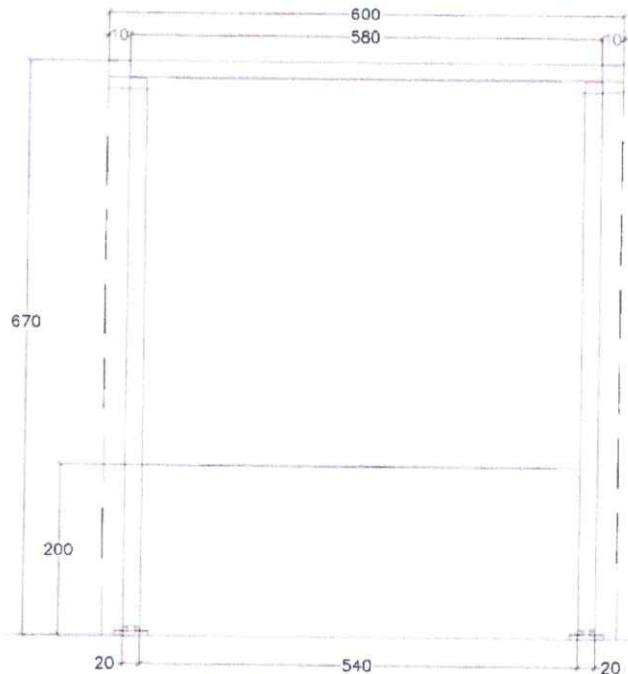

FRONT VIEW

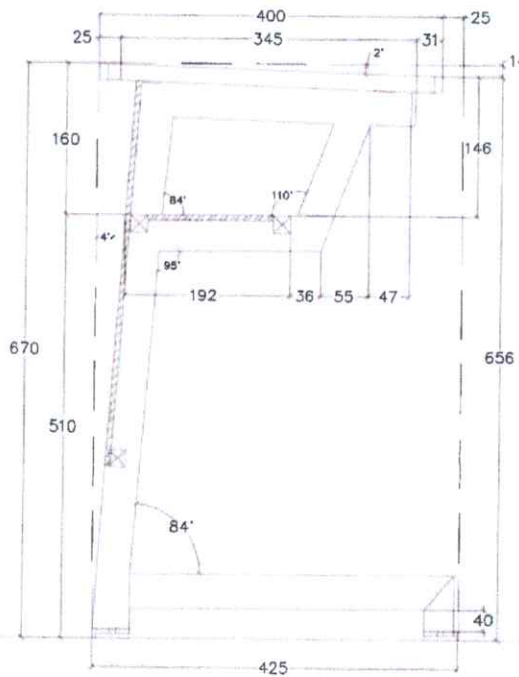

SIDE SECTION VIEW

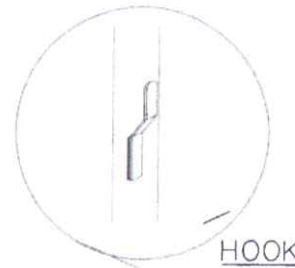

HOOK

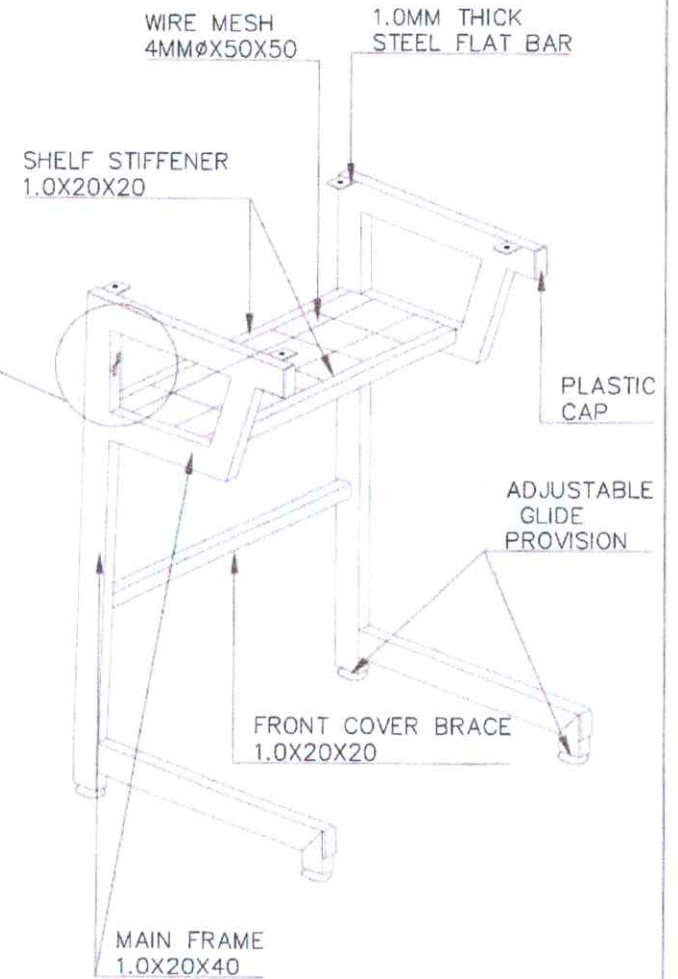

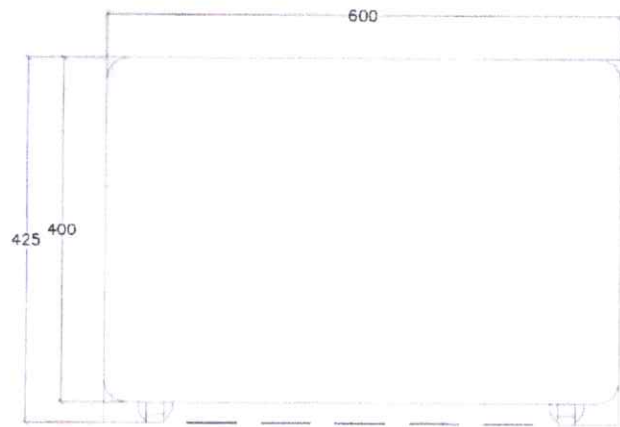

TABLE FRAMING PERSPECTIVE VIEW

| | | | | | | | |
|---|---|---|---|--|---|--|------------------------------|
| <p>REPUBLIC OF THE PHILIPPINES</p>  <p>DepEd DEPARTMENT OF EDUCATION EDUCATION FACILITIES DIVISION Meralco Avenue, Pasig City</p> | <p>DESIGNED BY: <i>[Signature]</i> MR. RAYMOND G. ALABADO ARCHITECT</p> | <p>RECOMMENDING APPROVAL: <i>[Signature]</i> ENGR. RICHARD S. PANGAN CHIEF, EDUCATION FACILITIES DIVISION</p> | <p>APPROVED BY: <i>[Signature]</i> ENGR. EDUARDO V. DEL ROSARIO III Undersecretary for School Infrastructure and Facilities</p> | <p>CONCURRED BY: <i>[Signature]</i> ENGR. CARLOS G. GARCIA Undersecretary for Curriculum Development</p> | <p>PROJECT TITLE: LEARNER'S TABLE (WOOD & STEEL)</p> | <p>SHEET CONTENTS TOP VIEW FRONT VIEW SIDE SECTION VIEW FRAMING PERSPECTIVE VIEW</p> | <p>SHEET NO: 2 3</p> |
|---|---|---|---|--|---|--|------------------------------|

DEPED SECONDARY SINGLE LEARNER'S TABLE



TOP VIEW

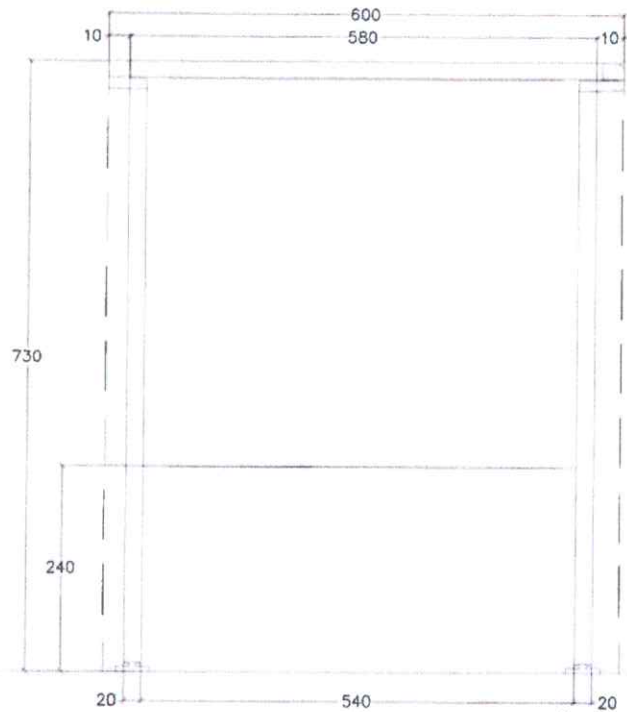

FRONT VIEW

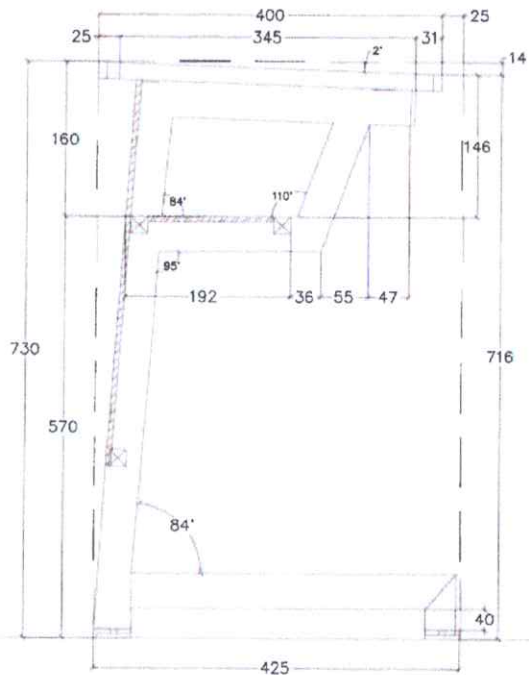

SIDE SECTION VIEW

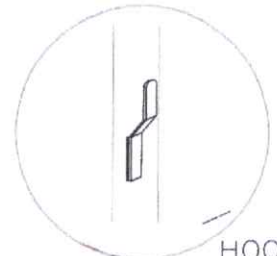

HOOK

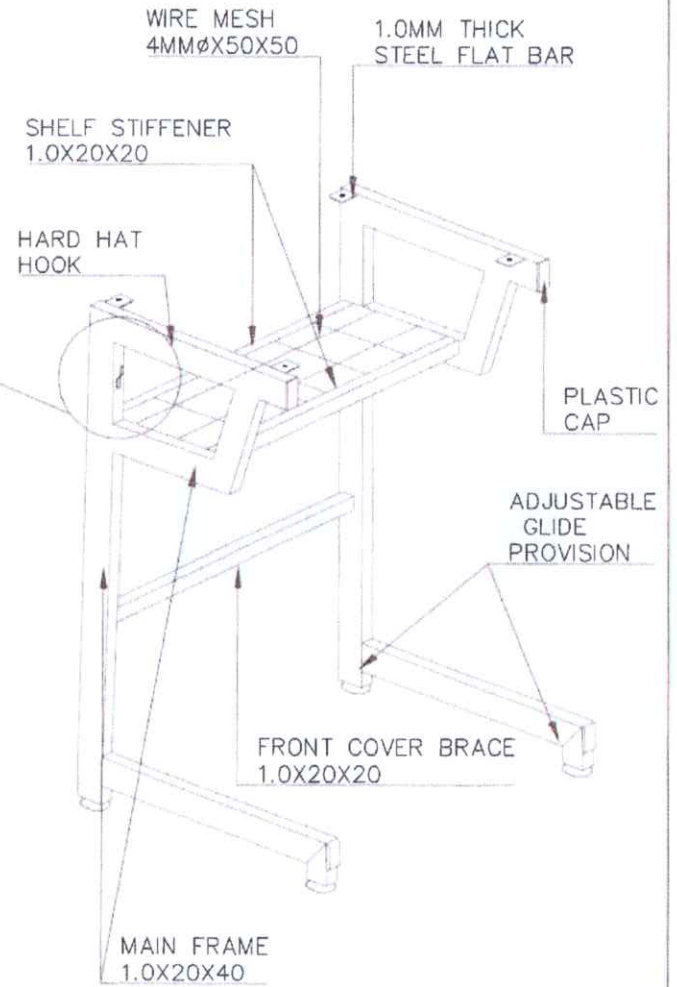
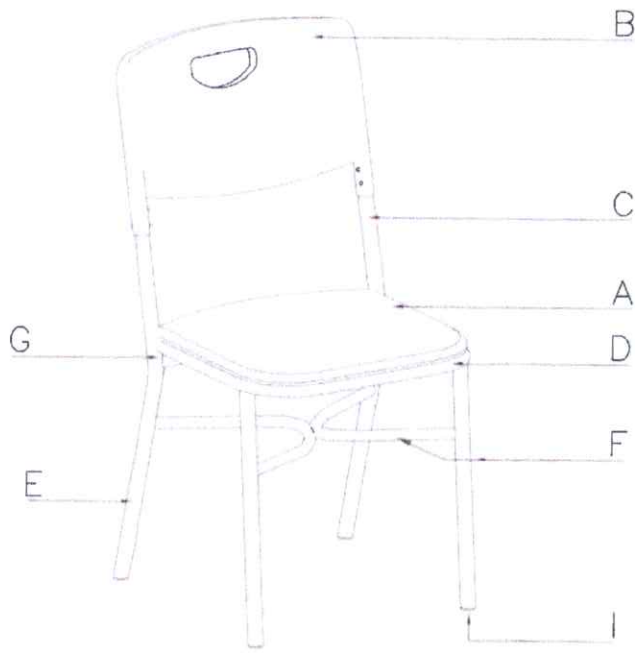

TABLE FRAMING PERSPECTIVE VIEW

| | | | | | | | |
|--|---|--|---|--|---|---|------------------------------|
| <p>REPUBLIC OF THE PHILIPPINES DepEd DEPARTMENT OF EDUCATION EDUCATION FACILITIES DIVISION HERALDO A AVENUE, PASIG CITY</p> | <p>DRAWN BY: <i>[Signature]</i> ENGR. RAYMOND G. KLARAS ARCHITECT</p> | <p>RECOMMENDING APPROVAL: <i>[Signature]</i> ENGR. ANWARUL KARIM BIN ANWAR CHIEF - EDUCATION FACILITIES DIVISION</p> | <p>APPROVED BY: <i>[Signature]</i> TIMACO V. DENISING III Undersecretary for School Infrastructure and Facilities</p> | <p>CONCURRED BY: <i>[Signature]</i> GINA M. MONTE Undersecretary for Curriculum and Teaching</p> | <p>PROJECT TITLE: LEARNER'S TABLE (WOOD & STEEL)</p> | <p>SHEET CONTENTS: TOP VIEW FRONT VIEW SIDE SECTION VIEW FRAMING PERSPECTIVE VIEW</p> | <p>SHEET NO: 3 3</p> |
|--|---|--|---|--|---|---|------------------------------|



1 ISOMETRIC VIEW OF LEARNER'S CHAIR
1 SCALE -M

| 1 TECHNICAL SPECIFICATIONS OF LEARNER'S CHAIR | | |
|---|--------------------|---|
| MARK | COMPONENTS | SPECIFICATIONS |
| A | SEAT | BLOW MOLDED PLASTIC HIGH-DENSITY POLYETHYLENE (HDPE) |
| B | BACKREST | BLOW MOLDED PLASTIC HIGH-DENSITY POLYETHYLENE (HDPE) |
| C | BACK SUPPORT | BI PIPE TUBE 1.0MMX22MMØ |
| D | SEAT SUPPORT | BI PIPE TUBE 1.0MMX19MMØ |
| E | BACK LEG | BI PIPE TUBE 1.0MMX22MMØ |
| F | FRONT LEG/BRACE | BI PIPE TUBE 1.0MMX22MMØ |
| G | LOWER SEAT SUPPORT | BI PIPE TUBE 1.0MMX19MMØ |
| I | COVER CAP | PLASTIC GLIDE |
| | HDPE TO STEEL: | BACK HDPE TO STEEL - SELF TAPPING SCREW/RIVET |
| | | SEAT HDPE TO STEEL - 1MM THK 25MMX30MM FLAT BAR, M6X12 |

SCHEDULE OF FINISHES

| | |
|------------------------|---|
| SEAT PANEL BACKREST | HIGH-DENSITY POLYETHYLENE (HDPE) PLASTIC (BLOW MOLDED) |
| METAL/STEEL TUBULAR | POWDER COATED (BLACK); SMOOTH, GLOSSY FINISH |
| HDPE COLOR | REFER TO COLOR CODE PANTONE 4665C OR COLOR HEX: #cda788 / RGB: 205, 167, 136 / CMYK: 0%, 19%, 34%, 20% |

DIMENSIONS OF LEARNER'S CHAIR (mm)
(TOLERANCE ± 10mm)

| COMPONENTS | DIMENSIONS | |
|------------------|------------|-----------|
| | ELEMENTARY | SECONDARY |
| SEAT HEIGHT | 390 | 430 |
| SEAT DEPTH | 380 | 380 |
| SEAT WIDTH | 370 | 370 |
| BACK REST HEIGHT | 700 | 800 |
| BACK REST WIDTH | 410 | 410 |

| | | | | | | | |
|---|---|---|---|---|--|--|------------------------|
| <p>REPUBLIC OF THE PHILIPPINES DEPARTMENT OF EDUCATION BUREAU OF EDUCATION FACILITIES DIVISION MERRILL ROAD, PASAY CITY</p> | <p>DRAWN BY: <i>[Signature]</i> JULYAN G. ALABADO ARCHITECT</p> | <p>RECOMMENDING APPROVAL: <i>[Signature]</i> ENGR. ANABEL R. [Name] CHIEF - EDUCATION FACILITIES DIVISION</p> | <p>APPROVED BY: <i>[Signature]</i> TIMACO V. DENISING III Undersecretary for School Infrastructure and Facilities</p> | <p>CONCURRED BY: <i>[Signature]</i> [Name] Undersecretary for Curriculum and Teaching</p> | <p>PROJECT TITLE: LEARNER'S CHAIR (HDPE & STEEL)</p> | <p>SHEET CONTENTS: TECHNICAL SPECIFICATION SCHEDULE OF FINISHES EDGING APPLICATION DIMENSIONS ISOMETRIC VIEW</p> | <p>SHEET NO: 1 / 5</p> |
|---|---|---|---|---|--|--|------------------------|

DEPED ELEMENTARY LEARNER'S CHAIR

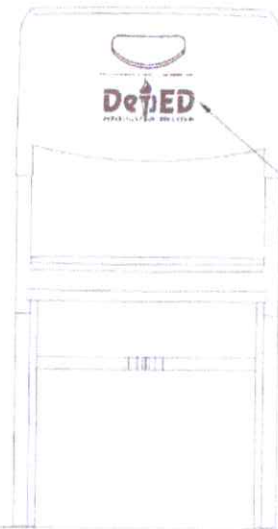
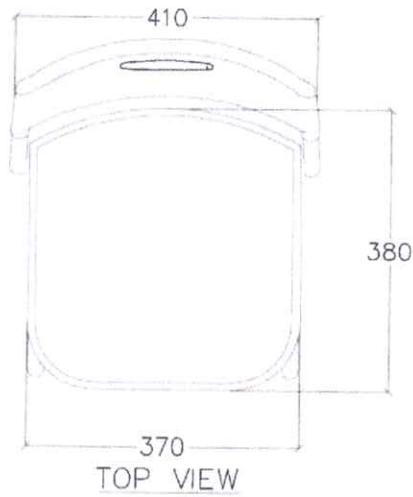

**DEPED LOGO
SPECIFICATIONS
FOR ALL
LEARNER AND
TEACHER'S CHAIR**

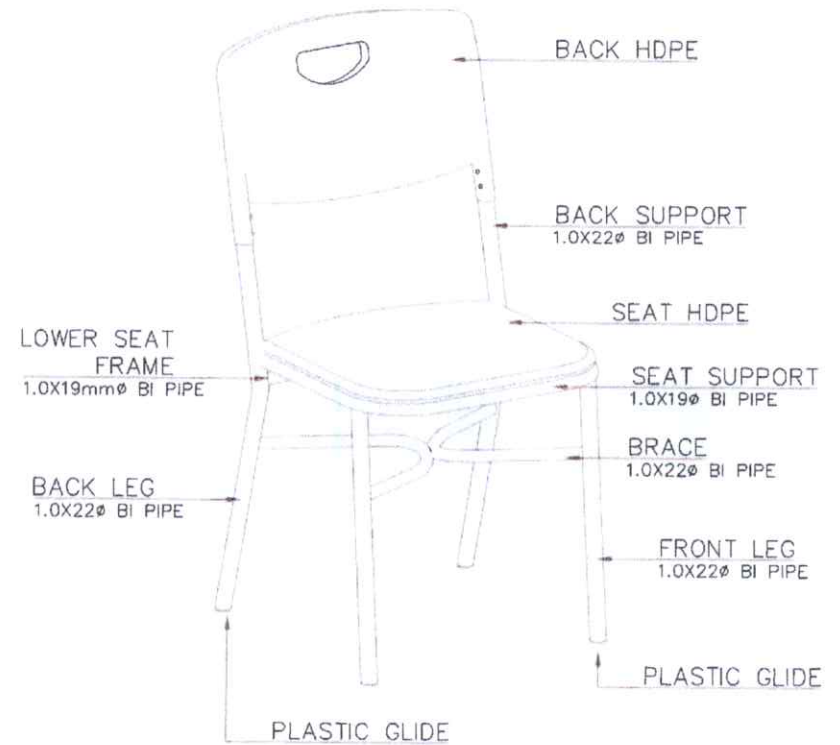
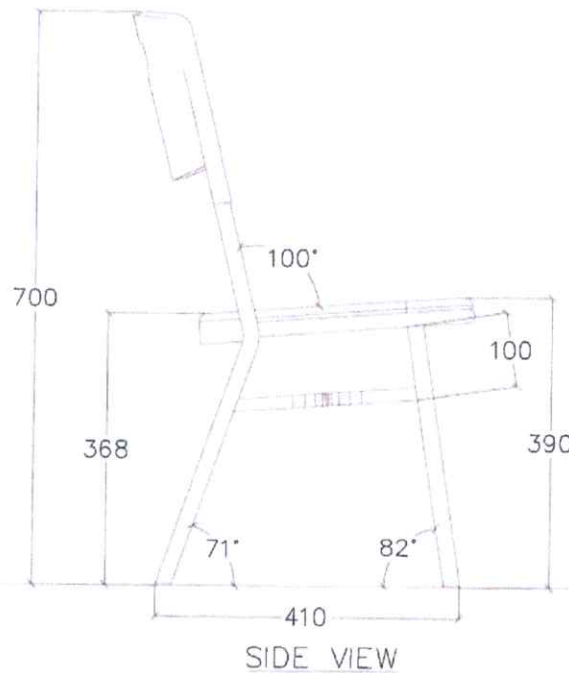
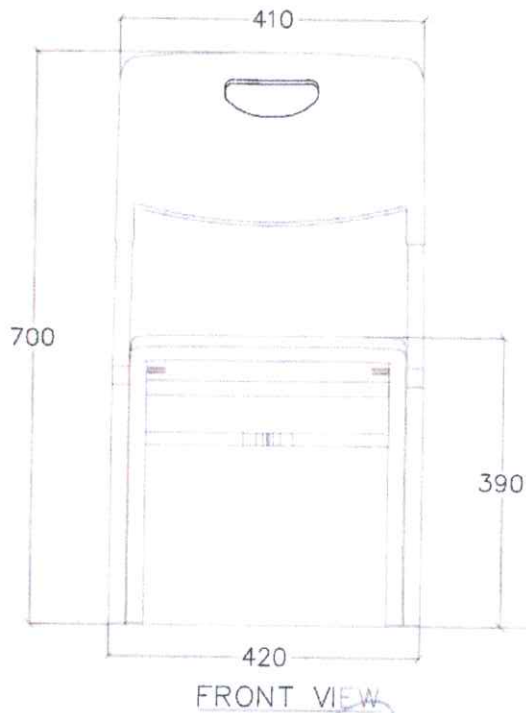

LEARNER'S CHAIR
PERSPECTIVE VIEW

| | | | | | | | |
|--|---|--|---|---|---|--|---------------------------------|
| <p>REPUBLIC OF THE PHILIPPINES DepED DEPARTMENT OF EDUCATION EDUCATION FACILITIES DIVISION MERRILL AVENUE, PASIG CITY</p> | <p>DRAWN BY:</p> <p>JEFF RAYMUNO G. ALARISO ARCHITECT</p> | <p>RECOMMENDING APPROVAL:</p> <p>ENGR. ANABELLE R. JIMENEZ CHIEF - EDUCATION FACILITIES DIVISION</p> | <p>APPROVED BY:</p> <p>ENGR. MACARIO S. DENIN, II Undersecretary for School Infrastructure and Facilities</p> | <p>CONCURRED BY:</p> <p>GINA D. LONONG Undersecretary for Curriculum and Teaching</p> | <p>PROJECT TITLE:</p> <p>LEARNER'S CHAIR (HDPE & STEEL)</p> | <p>SHEET CONTENTS</p> <p>ELEMENTARY LEARNER'S CHAIR: -PERSPECTIVE VIEW -TOP VIEW -REAR VIEW -FRONT VIEW -SIDE VIEW</p> | <p>SHEET NO.</p> <p>2 5</p> |
| | | | | | | | |

DEPED ELEMENTARY LEARNER'S CHAIR

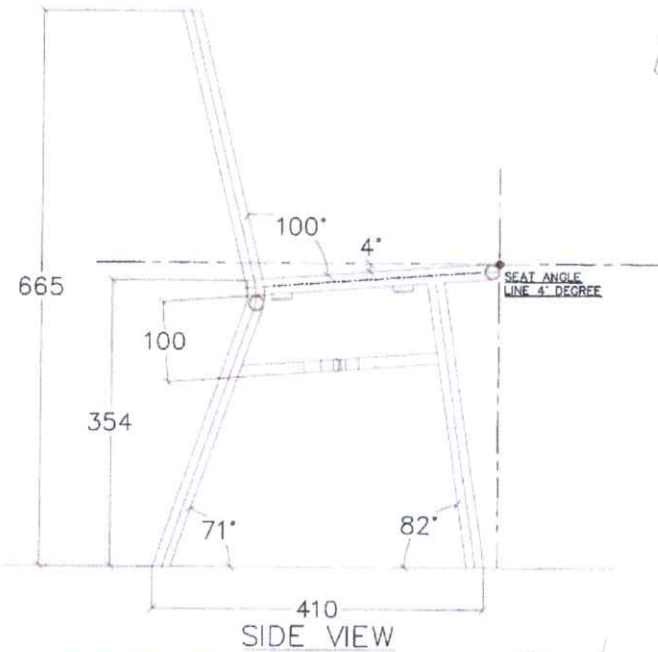
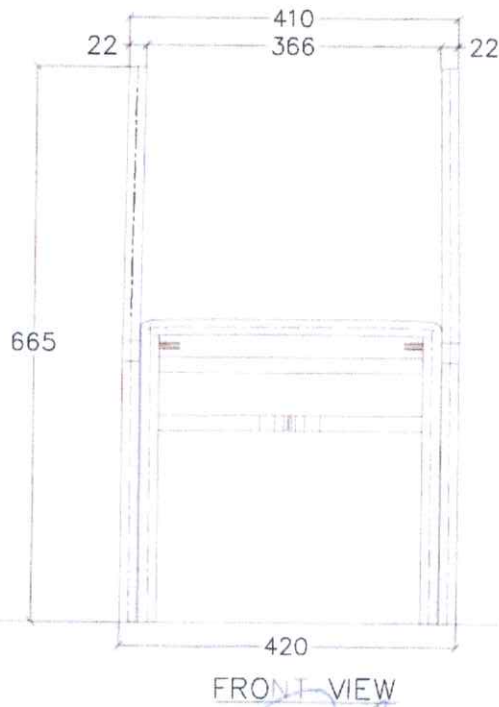
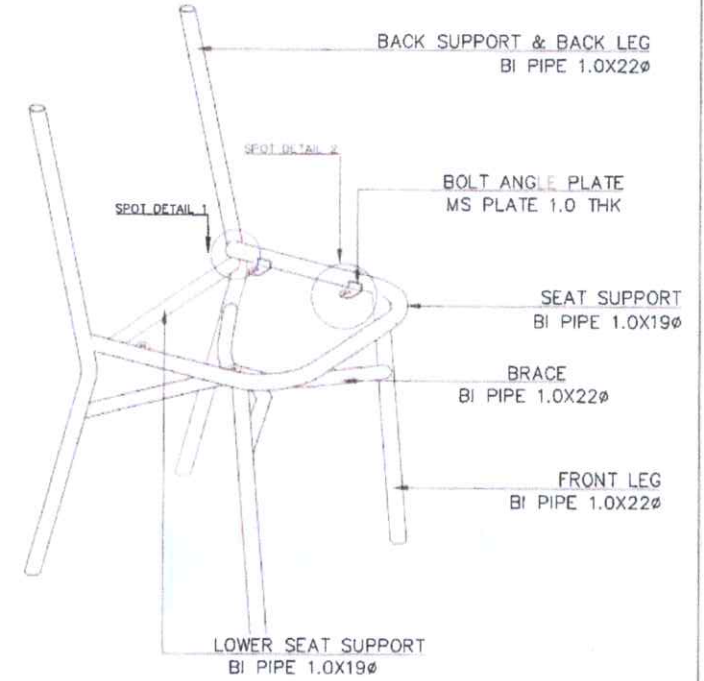
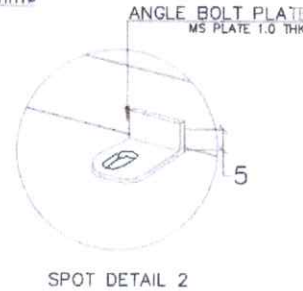
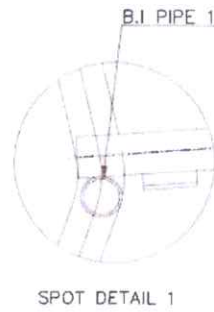
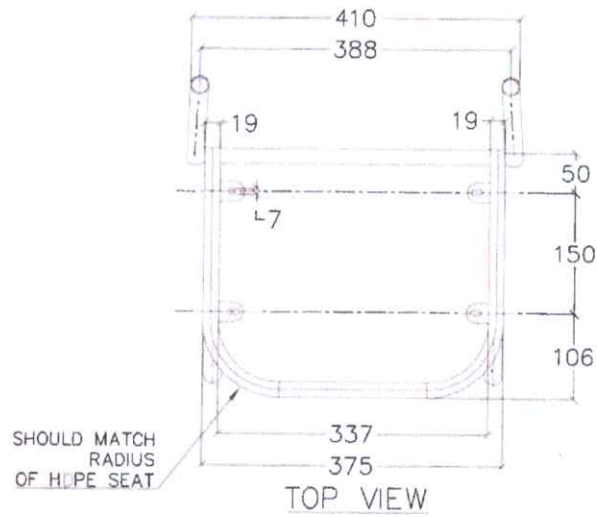

| | | | | | | | |
|---|---|--|---|---|---|---|---------------------|
| <p>REPUBLIC OF THE PHILIPPINES DepED DEPARTMENT OF EDUCATION EDUCATIONAL SERVICES DIVISION NATIONAL OFFICE, PASAY CITY</p> | DESIGN BY: RAYMOND G. ALABASO ARCHITECT | RECOMMENDING APPROVAL: ENGR. ANNA L. DENISING III CHIEF - PLANNING FACILITIES DIVISION | APPROVED BY: RENATO S. DENISING III Undersecretary for School Infrastructure and Facilities | CONCURRED BY: LINA O. GONONG Undersecretary for Curriculum and Learning | PROJECT TITLE: LEARNER'S CHAIR (HDPE & STEEL) | SHEET CONTENTS: ELEMENTARY LEARNER'S CHAIR -CHAIR FRAME (TOP, FRONT, SIDE VIEWS) -PERSPECTIVE VIEW -DETAILS | SHEET NO. 3 5 |
| | | | | | | | |

DEPED SECONDARY LEARNER'S CHAIR

DEPED LOGO SPECIFICATIONS FOR ALL LEARNER AND TEACHER'S CHAIR

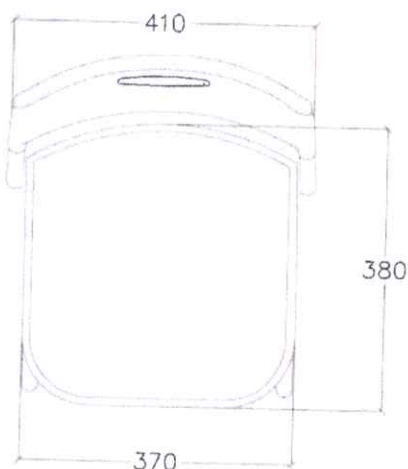

TOP VIEW

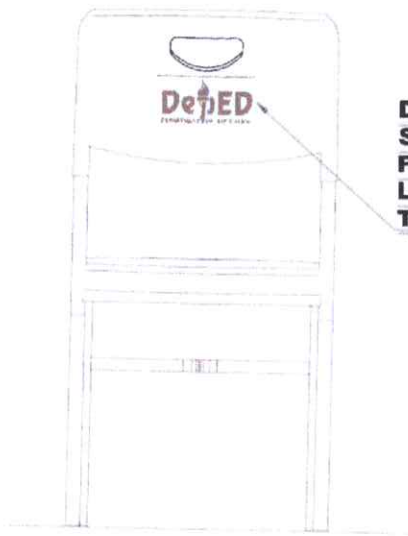

REAR VIEW

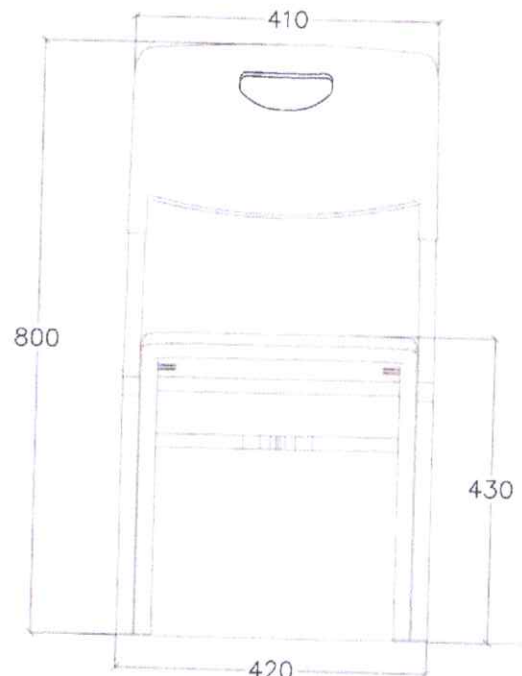



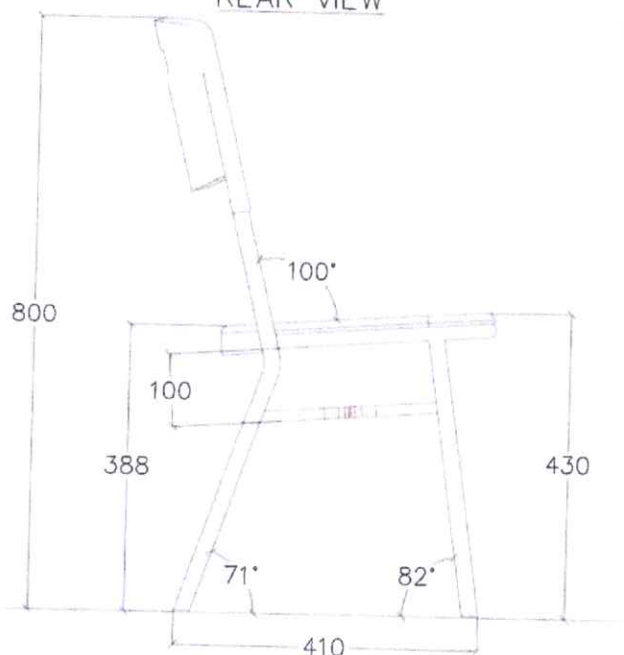

FRONT VIEW

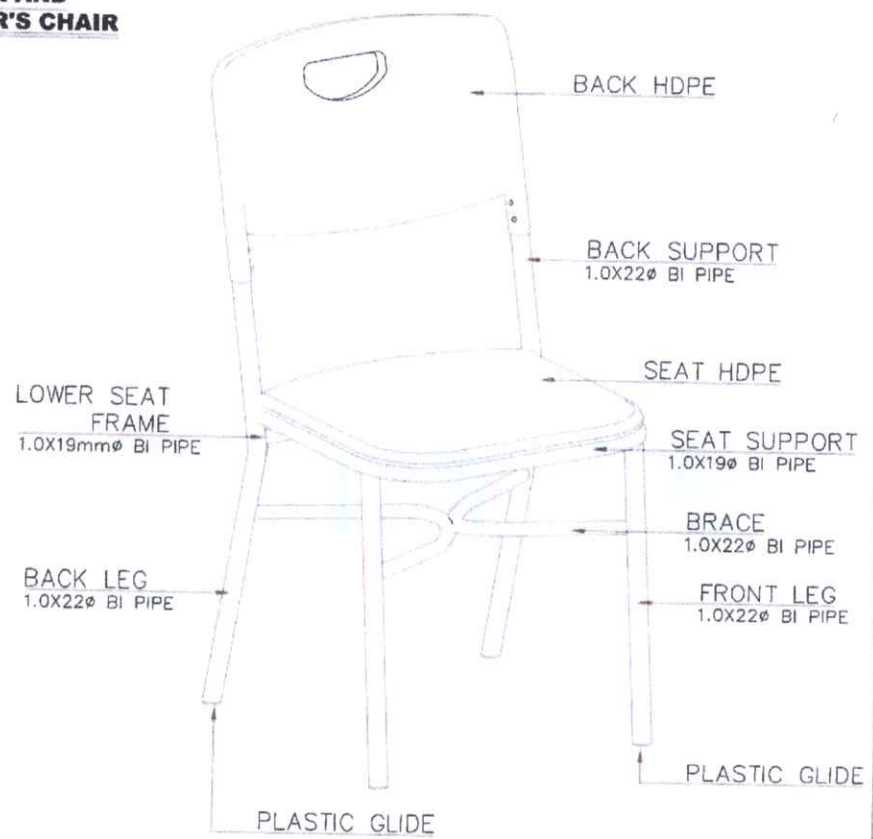

SIDE VIEW



LEARNER'S CHAIR PERSPECTIVE VIEW

| | | | | | | | |
|---|---|---|---|--|---|--|----------------------------------|
| <p>REPUBLIC OF THE PHILIPPINES</p>  <p>DEPARTMENT OF EDUCATION EDUCATIONAL FACILITIES DIVISION MORONG CITY, PANGASINAN</p> | <p>DRAWN BY:</p>  <p>J. J. WYNDYND G. ALABAN ARCHITECT</p> | <p>RECOMMENDING APPROVAL:</p>  <p>ENGR. ANABELLE P. BANGAYAN CHIEF - EDUCATION FACILITIES DIVISION</p> | <p>APPROVED BY:</p>  <p>DEPED DIVISION OFFICE MORONG CITY, PANGASINAN</p> | <p>CONCURRED BY:</p>  <p>UNDERSECRETARY FOR CURRICULUM AND TEACHING</p> | <p>PROJECT TITLE:</p> <p>LEARNER'S CHAIR (HDPE & STEEL)</p> | <p>SHEET CONTENTS</p> <p>SECONDARY LEARNER'S CHAIR: - PERSPECTIVE VIEW - TOP VIEW - REAR VIEW - FRONT VIEW - SIDE VIEW</p> | <p>SHEET NO.:</p> <p>4 5</p> |
|---|---|---|---|--|---|--|----------------------------------|

DEPED SECONDARY LEARNER'S CHAIR

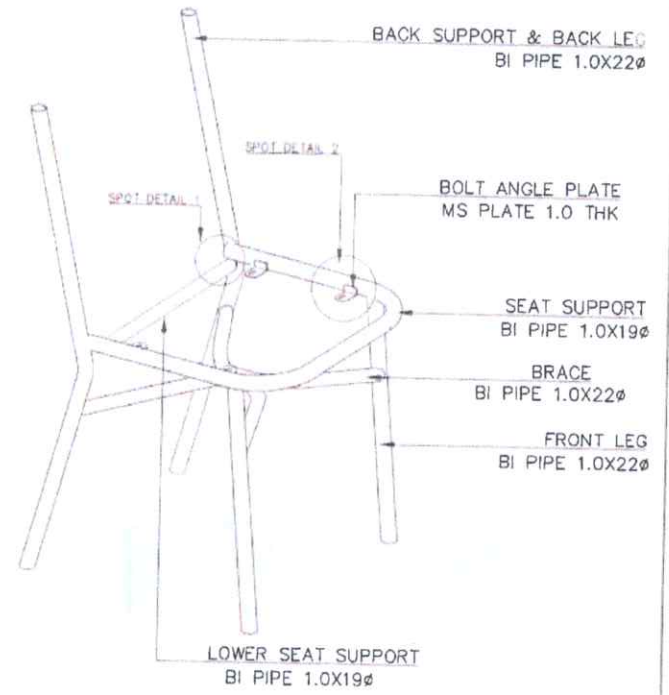
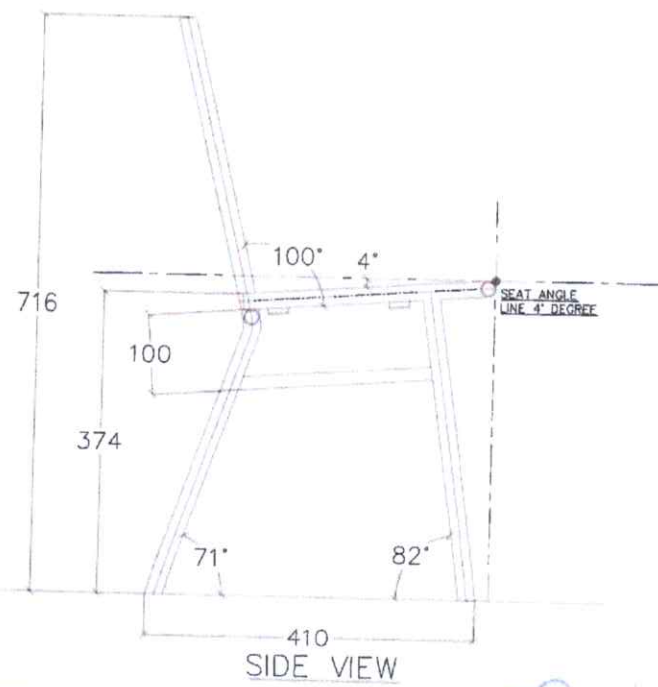
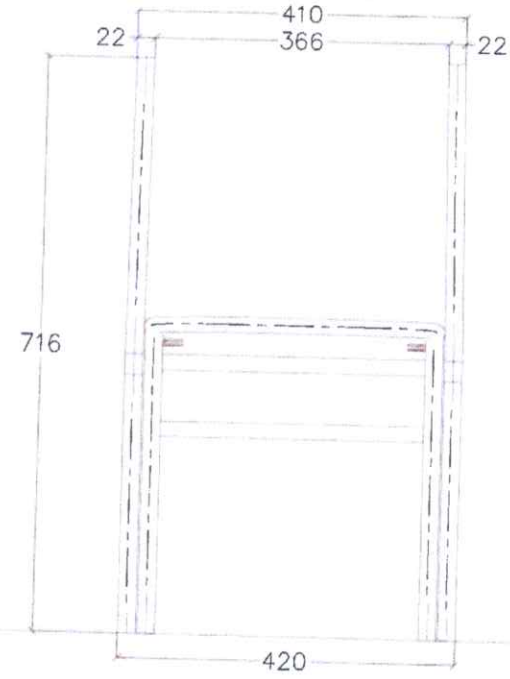
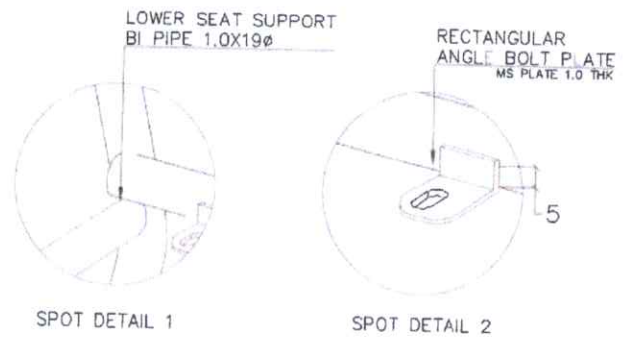
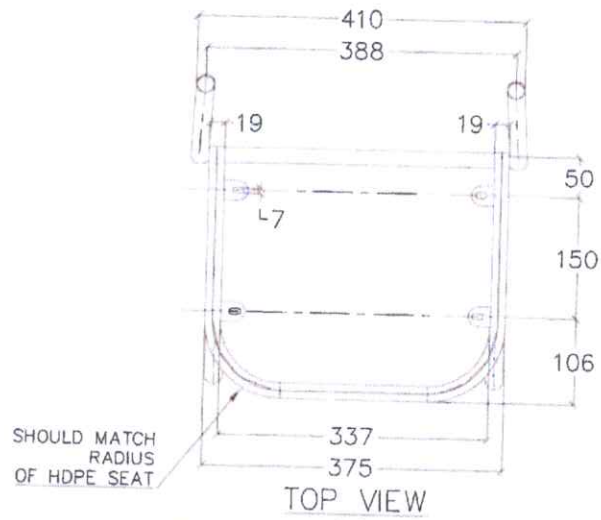

| | | | | | | | |
|--|---|--|--|---|---|---|----------------------|
| <p>REPUBLIC OF THE PHILIPPINES DepED DEPARTMENT OF EDUCATION EDUCATION FACILITIES DIVISION BARCELONA AVENUE, PASIG CITY</p> | DRAWN BY: RAYMOND G. ALABAS ARCHITECT | RECOMMENDING APPROVAL: ENGR. ARNEL L. ESPINOSA CHIEF - EDUCATION FACILITIES DIVISION | APPROVED BY: ENGR. MAC L. DENISING III Undersecretary for School Infrastructure and Facilities | CONCURRED BY: GINA D. GONING Undersecretary for Curriculum and Teaching | PROJECT TITLE: LEARNER'S CHAIR (HDPE & STEEL) | SHEET CONTENTS: SECONDARY LEARNER'S CHAIR - CHAIR FRAME (TOP, FRONT, SIDE VIEWS) - PERSPECTIVE VIEW - DETAILS | SHEET NO.: 5 5 |
| | | | | | | | |

| 1 TECHNICAL SPECIFICATIONS OF TEACHER'S TABLE | | |
|---|--------------------|---|
| MARK | COMPONENTS | SPECIFICATIONS |
| A | TABLE TOP | 18MM THK TOP BOARD ROUND CORNER'S (1 SIDE 1.0MM THK HIGH PRESSURE LAMINATE /1 SIDE VARNISH FINISHES ON MARINE PLYWOOD) |
| B | EDGING | 2.0MM THICK PVC EDGING |
| C | SIDE COVER | 6.0MM THICK MARINE PLYWOOD W/ HIGH PRESSURE LAMINATE |
| D | FRONT COVER | 6.0MM THICK MARINE PLYWOOD W/ HIGH PRESSURE LAMINATE |
| E | PULL OUT DRAWER | DRAWER FACE : 1 SIDE 1.0MM THK HIGH PRESSURE LAMINATE / 1 SIDE VARNISH FINISHES ON 18MM THICK MARINE PLYWOOD DRAWER BOX : 12mm THK MARINE PLYWOOD W/ SOLID WOOD EDGING VARNISH FINISHED DRAWER LOCK : 1 LOCK ONLY PER TABLE, |
| | DRAWER GUIDE | 400MM LONG RAIL GUIDE (BALL BEARING TYPE) |
| F | LEG | 1.0MMTHKX30MMX30MM STEEL TUBULAR |
| G | BRACES | 1.0MMTHKX30MMX30MM STEEL TUBULAR |
| H | ADJUSTABLE LEVELER | 8MMØ THREAD WITH 38MMØ PLASTIC BASE |
| | CONNECTION | STEEL TO STEEL: FULL WELDING WOOD TO STEEL: THREADED NUTS E-TYPE HEX M6 X13mm LENGTH (TABLE TOP) BLIND RIVETS (FRONT COVER / SIDE COVER) WOOD TO WOOD: WOOD GLUE AND FINISHING NAILS |

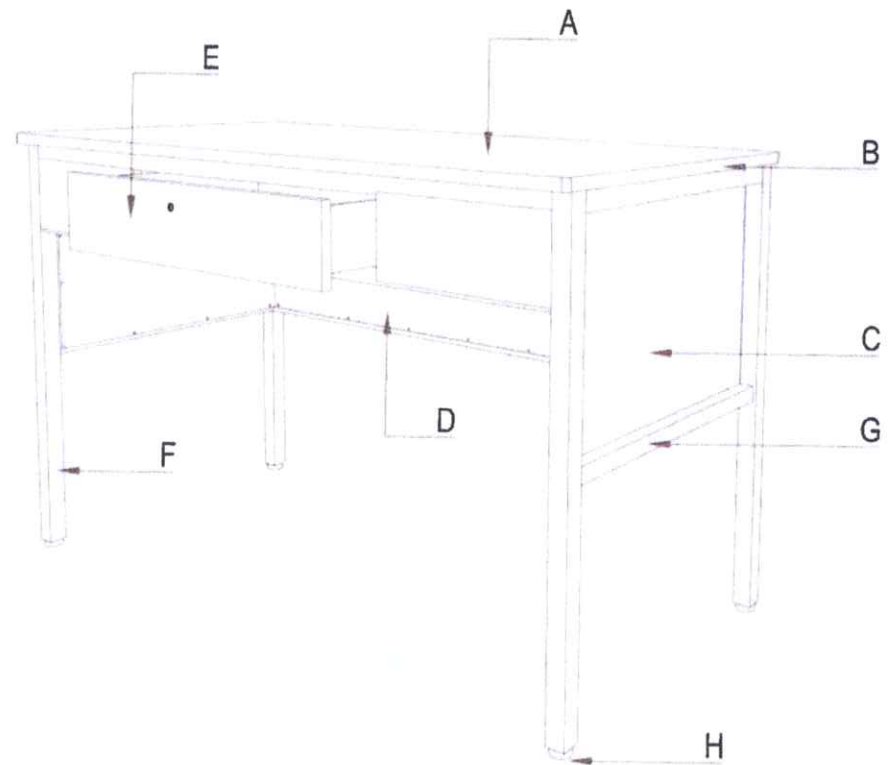

1 ISOMETRIC VIEW OF TEACHER'S TABLE
1 SCALE

2a SCHEDULE OF FINISHES

| | |
|---------------------|--|
| TOP BOARD | 18MM THK TOP BOARD ROUND CORNER'S (1 SIDE 1.0MM THK HIGH PRESSURE LAMINATE /1 SIDE VARNISH FINISHES ON MARINE PLYWOOD) |
| EDGING | 2.0MM THICK PVC EDGING |
| METAL/STEEL TUBULAR | POWDER COATED (BLACK); SMOOTH, GLOSSY FINISH |
| LAMINATE COLOR | PANTONE 729C OR COLOR HEX #ba7c45 / RGB 186, 124, 69 / CMYK 0%, 33%, 63%, 27% WITH WOOD GRAIN (SERANO BEECH OR EQUIVALENT) |

3 DIMENSIONS OF TEACHER'S TABLE (mm)
(TOLERANCE ± 10mm)

| MARK | COMPONENTS | DIMENSIONS |
|------|--------------|------------|
| a | TABLE HEIGHT | 750 |
| b | TABLE LENGTH | 1200 |
| c | TABLE WIDTH | 600 |

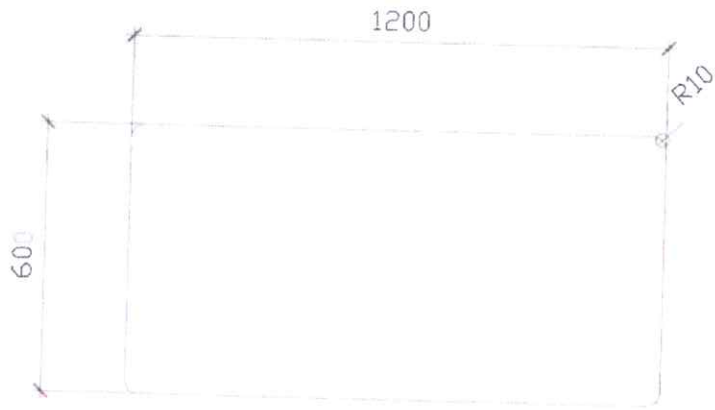

PLAN

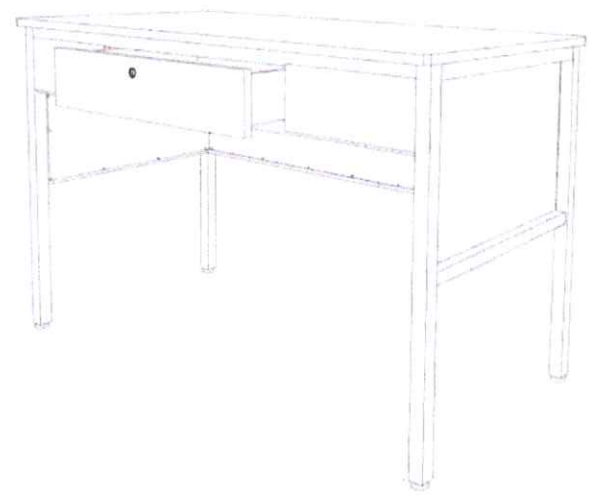

PERSPECTIVE

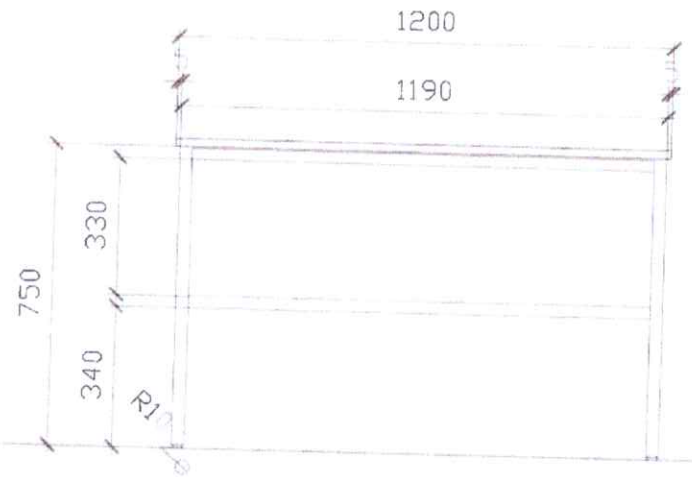

FRONT ELEV.

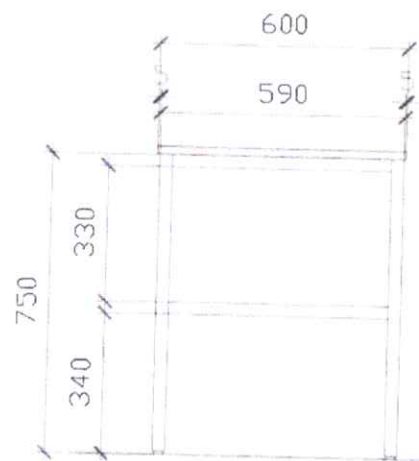

RIGHT SIDE ELEVATION

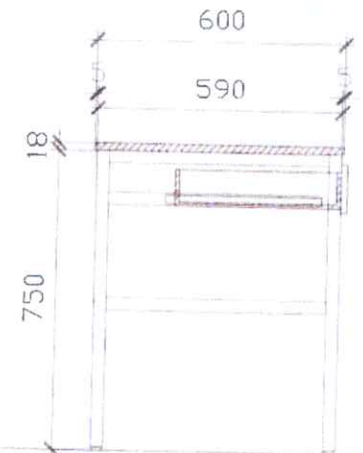



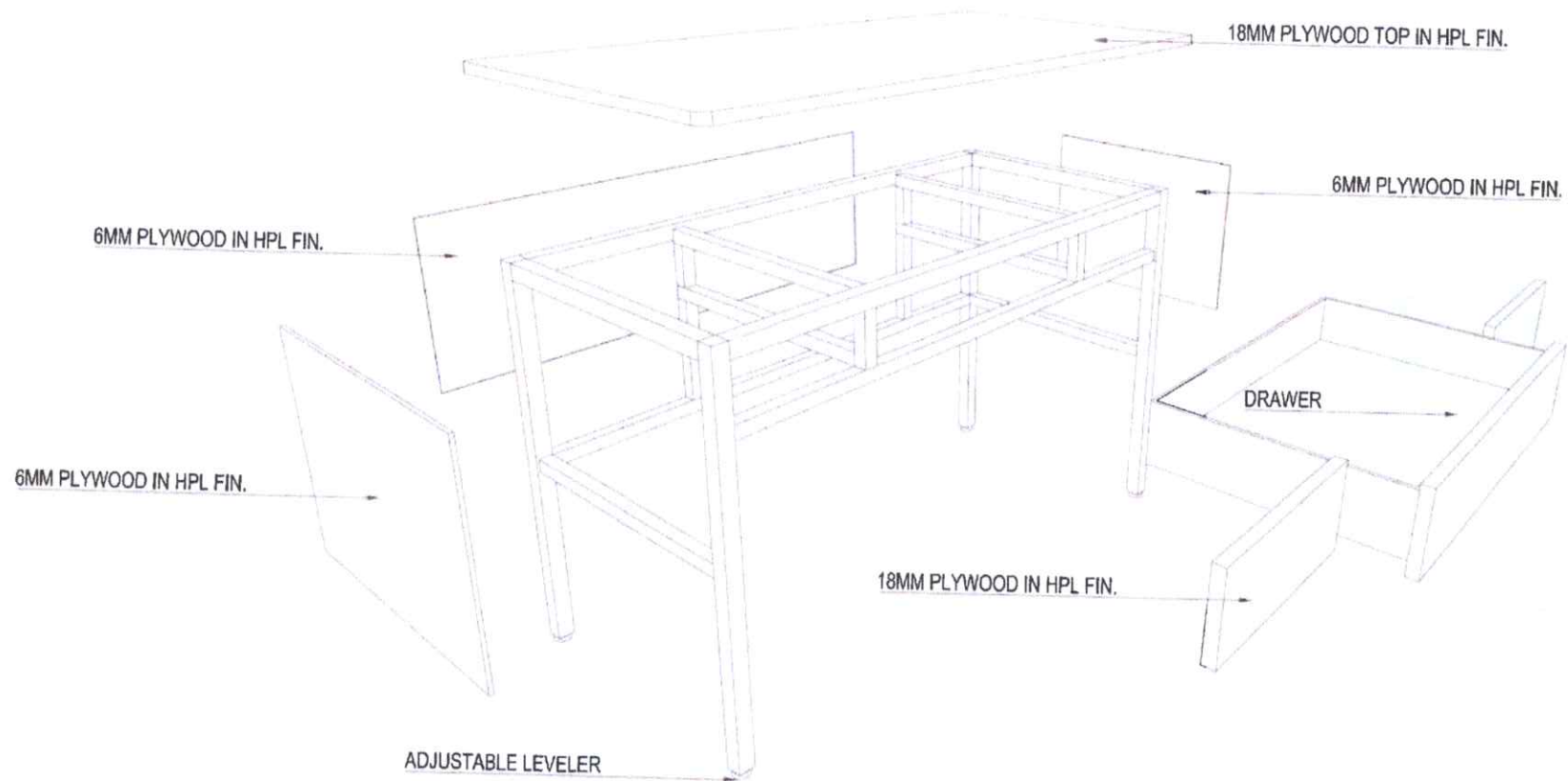

SECTION

| | | | | | | | |
|---|--|---|---|---|---|--|---|
| <p>REPUBLIC OF THE PHILIPPINES DepED DEPARTMENT OF EDUCATION EDUCATION FACILITIES DIVISION MARCELINO AVENA, PASAY CITY</p> | DRAWN BY: RAYMOND C. ALARIDO ARCHITECT | RECOMMENDING APPROVAL: ENGR. ANABELLE M. JIMENEZ CHIEF, EDUCATION FACILITIES DIVISION | APPROVED BY: RAMON V. DENISING II Undersecretary for School Infrastructure and Facilities | CONCURRED BY: GINA D. GARING Undersecretary for Curriculum and Teaching | PROJECT TITLE: TEACHER'S TABLE (WOOD & STEEL) | SHEET CONTENTS: PLAN PERSPECTIVE FRONT ELEVATION SECTION | SHEET NO.: <div style="border: 1px solid black; border-radius: 50%; width: 30px; height: 30px; display: flex; flex-direction: column; align-items: center; justify-content: center;"> 2 5 </div> |
| | | | | | | | |

TEACHER'S TABLE

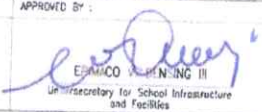

EXPLODED VIEW

| | | | | | | | |
|--|--|---|--|--|---|--|---------------------------------|
| <p>REPUBLIC OF THE PHILIPPINES</p>  <p>DEPARTMENT OF EDUCATION EDUCATIONAL LITERALS DIVISION SCHOOL FACILITIES DIVISION</p> | <p>DRAWN BY:</p>  <p>J. ALAPADO ARCHITECT</p> | <p>RECOMMENDING APPROVAL:</p>  <p>ENGR. ANABELLE P. FAJANA CHIEF - EDUCATION FACILITIES DIVISION</p> | <p>APPROVED BY:</p>  <p>EDUARDO LAPENING III Undersecretary for School Infrastructure and Facilities</p> | <p>CONCURRED BY:</p>  <p>GINA O. GONDONG Undersecretary for Curriculum and Teaching</p> | <p>PROJECT TITLE:</p> <p>TEACHER'S TABLE (WOOD & STEEL)</p> | <p>SHEET CONTENTS</p> <p>TEACHER'S TABLE EXPLODED VIEW</p> | <p>SHEET NO:</p> <p>3 5</p> |
|--|--|---|--|--|---|--|---------------------------------|

METAL FRAMING DETAIL

30X30X1MM TUBULAR
IN BLACK POWDER
COAT FIN.

30X30X1MM TUBULAR
IN BLACK POWDER
COAT FIN.



PERSPECTIVE

30X30X1MM TUBULAR
IN BLACK POWDER
COAT FIN.

30X30X1MM TUBULAR
IN BLACK POWDER
COAT FIN.

30X30X1MM TUBULAR
IN BLACK POWDER
COAT FIN.

30X30X1MM TUBULAR
POST IN BLACK POWDER
COAT FIN.

ADJUSTABLE
GLIDES

30X30X1MM TUBULAR
POST IN BLACK POWDER
COAT FIN.

30X30X1MM TUBULAR
BRACE IN BLACK POWDER
COAT FIN.

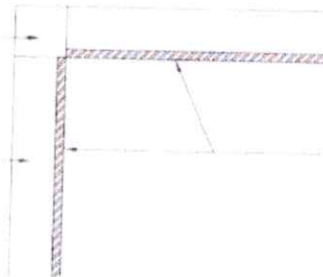

6MM PLYWOOD IN HPL FIN.

TOP VIEW SECTION



TOP

30X30X1MM TUBULAR
BRACE IN BLACK POWDER
COAT FIN.

30X30X1MM TUBULAR
IN BLACK POWDER
COAT FIN.

25mmX50mmX1MM THK.
POWDER COATED STEEL
FLAT BAR

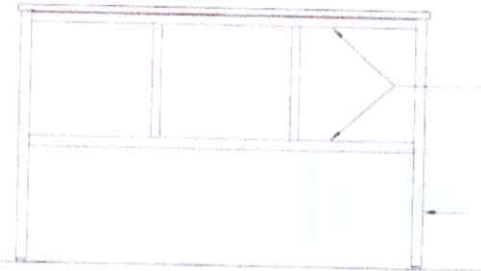

FRONT

30X30X1MM TUBULAR
IN BLACK POWDER
COAT FIN.

30X30X1MM TUBULAR
POST IN BLACK POWDER
COAT FIN.

590

SIDE VIEW

30X30X1MM TUBULAR
IN BLACK POWDER
COAT FIN.

30X30X1MM TUBULAR
POST IN BLACK POWDER
COAT FIN.

DESIGNED BY :

JET RAYMOND G. ALABADO
ARCHITECT

RECOMMENDING APPROVAL :

ENR. ANNABELLE D. ...
CHIEF - EDUCATION FACILITIES DIVISION

APPROVED BY :

MAIA ...
Undersecretary for School Infrastructure and Facilities

CONCURRED BY :

GINA O. GONONG
Undersecretary for Curriculum and Teaching

PROJECT TITLE :

TEACHER'S TABLE
(WOOD & STEEL)

SHEET CONTENTS

METAL FRAMING PERSPECTIVE

SHEET NO.

4

5

METAL CENTRAL DRAWER DETAIL

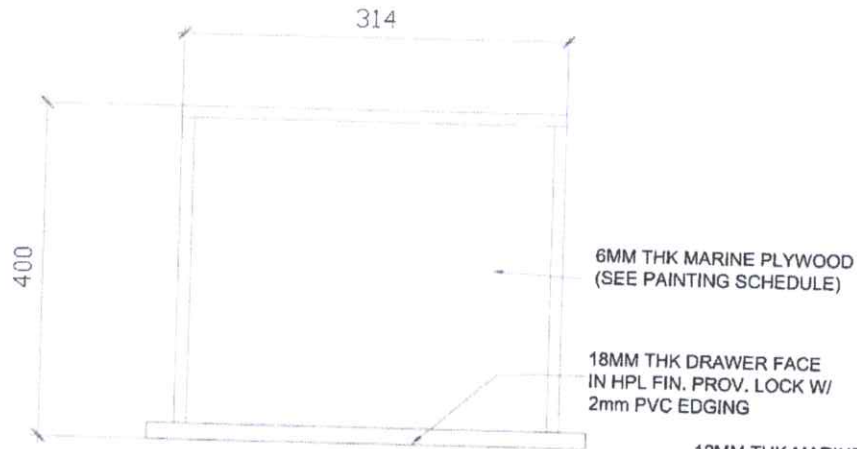

PLAN

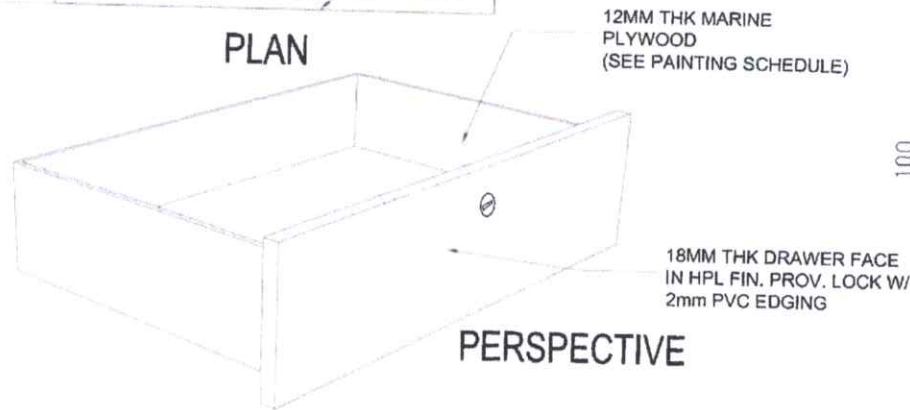

PERSPECTIVE

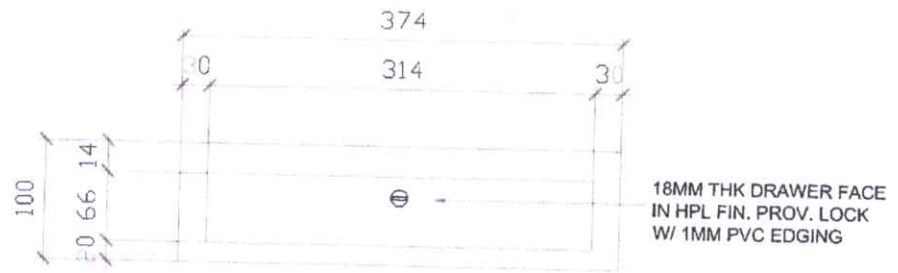

FRONT ELEV.

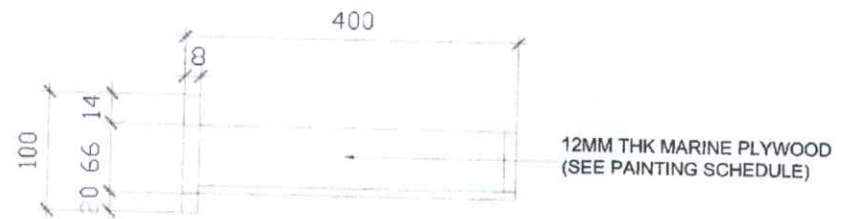

RIGHT SIDE VIEW

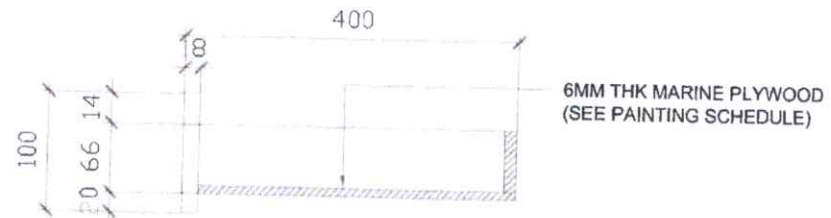

SECTION

PAINTING SCHEDULE

| | |
|-------------------|---|
| SANDING | ALL SURFACE TO BE COATED SHALL BE SMOOTHLY SANDED |
| 1ST COAT | OIL WOOD STAIN - WHITE OAK FULL COLOR |
| INTERMEDIATE COAT | LACQUER SANDING SEALER |
| TOP COAT | CLEAR GLOSS LACQUER (2 COATS) |

| | | | | | | | |
|---|---|--|--|--|---|--|---------------------------|
| <p>REPUBLIC OF THE PHILIPPINES DepED DEPARTMENT OF EDUCATION EDUCATION FACILITIES DIVISION NEEDS ASSESSMENT, PLANNING & DESIGN</p> | <p>DESIGNED BY:</p> <p>ARCHITECT</p> <p>RET. RAYMOND C. ARANASO</p> | <p>RECOMMENDING APPROVAL:</p> <p>ENR. WILSON M. GAN</p> <p>CHE - EDUCATION PLANNING DIVISION</p> | <p>APPROVED BY:</p> <p>ENR. WILSON M. GAN</p> <p>Undersecretary for School Infrastructure and Facilities</p> | <p>CONCURRED BY:</p> <p>GINA O. GONING</p> <p>Undersecretary for Curriculum and Teaching</p> | <p>PROJECT TITLE:</p> <p>TEACHER'S TABLE (WOOD & STEEL)</p> | <p>SHEET CONTENTS</p> <p>METAL DRAWER DETAIL -FRONT ELEVATION -SECTION -EXPLODED VIEW -PERSPECTIVE</p> | <p>SHEET NO.</p> <p>5</p> |
| | <p>5</p> | | | | | | |

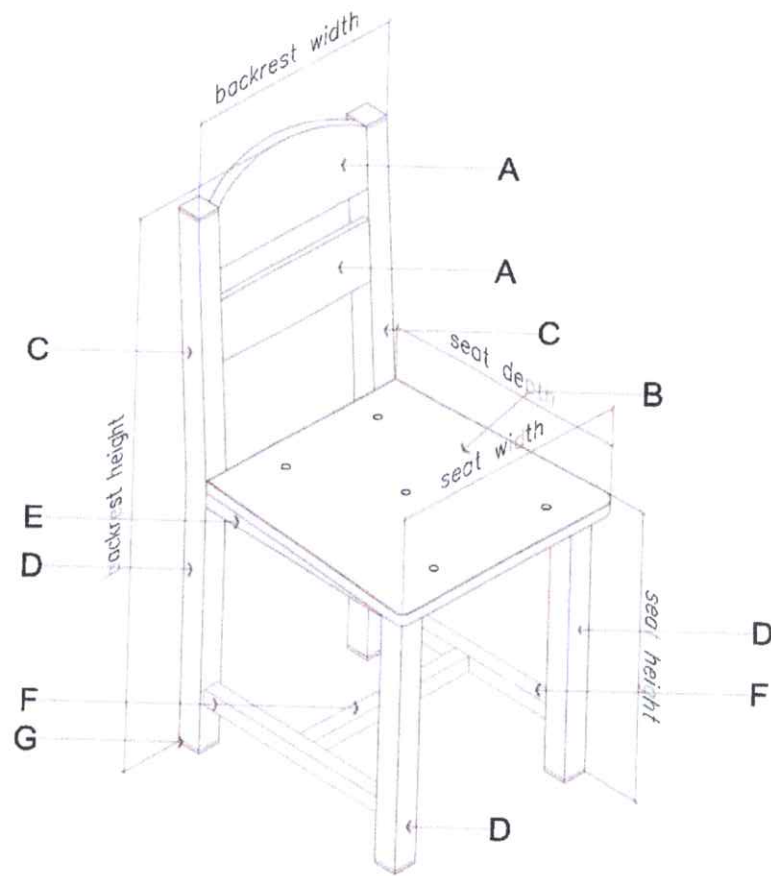

1 ISOMETRIC- TEACHER'S CHAIR
1 SCALE - M

NOTES:
WOOD GLUE SHALL BE APPLIED BEFORE INSERTING E-NUT INTO THE PLYWOOD
CORNERS OF BACKREST & SEAT PANELS MUST BE FOUNDED

1 TECHNICAL SPECIFICATIONS OF TEACHER'S CHAIR

| MARK | COMPONENT | SPECIFICATIONS |
|------|------------------|---|
| A | BACKREST | 18mm THK BACKREST PANEL (0.9mm THK HIGH PRESSURE LAMINATE ON MARINE PLYWOOD) W/ PVC EDGING |
| B | SEAT | 18mm THK SEAT PANEL (0.9mm THK HIGH PRESSURE LAMINATE ON MARINE PLYWOOD) W/ PVC EDGING & 5 VENT HOLES (12mm ϕ) |
| C | BACKREST SUPPORT | 0.8mm THK x 30mm x 30mm STEEL TUBULAR |
| D | LEG | 0.8mm THK x 30mm x 30mm STEEL TUBULAR |
| E | SEAT SUPPORT | 1mm THK x 30mm x 30mm STEEL TUBULAR |
| F | LEG BRACE | 1mm THK x 30mm x 30mm STEEL TUBULAR |
| G | FOOTING | HARD PLASTIC (BLACK) |
| | EDGING | PVC EDGING |
| | CONNECTION | |
| | WOOD TO STEEL | 1mm THK x 25mm x 75mm FLAT BAR (FOR BACKREST - 1) 1mm THK x 25mm x 50mm FLAT BAR (FOR BACKREST - 2) 1mm THK x 25mm x 50mm FLAT BAR (SEAT) M6 x13mm E-NUT AND SCREW (WOOD INSERT) |
| | STEEL TO STEEL | FULL WELDING - FOR TUBULAR TO TUBULAR CONNECTIONS; ADEQUATE WELDING - FOR B.I. PIPE TO FLAT BAR CONNECTIONS |

2 SCHEDULE OF FINISHES

| | |
|-----------------|---|
| BACKREST & SEAT | HIGH PRESSURE WOOD GRAIN LAMINATE W/ PVC EDGING |
| METAL / STEEL | POWDER COATED (BLACK); SMOOTH, GLOSSY FINISH |
| LAMINATE COLOR | SERANO BEECH OR EQUIVALENT |

3 DIMENSIONS OF TEACHER'S CHAIR (TOLERANCE OF ± 10 mm)

| COMPONENT | DIMENSIONS (mm) |
|-----------------|-----------------|
| SEAT HEIGHT | 440 |
| SEAT DEPTH | 400 |
| SEAT WIDTH | 400 |
| BACKREST HEIGHT | 850 |
| BACKREST WIDTH | 350 |

| | | | | | | | |
|--|--|--|---|---|---|--|---------------------------------------|
| REPUBLIC OF THE PHILIPPINES DepED DEPARTMENT OF EDUCATION EDUCATION FACILITIES DIVISION MERRALDO AVENUE, PASIG CITY | DRAWN BY: RAYMOND G. ALABAST ARCHITECT | RECOMMENDING APPROVAL: ENGR. AMABEL CHIEF, EDUCATION FACILITIES DIVISION | APPROVED BY: Undersecretary for School Infrastructure and Facilities | CONCURRED BY: Undersecretary for Curriculum and Teaching | PROJECT TITLE: TEACHER'S CHAIR (WOOD & STEEL) | SHEET CONTENTS: TECHNICAL SPECIFICATIONS OF TEACHER'S CHAIR SCHEDULE OF FINISHES DIMENSIONS ISOMETRIC VIEW | SHEET NO. 1 3 |
|--|--|--|---|---|---|--|---------------------------------------|

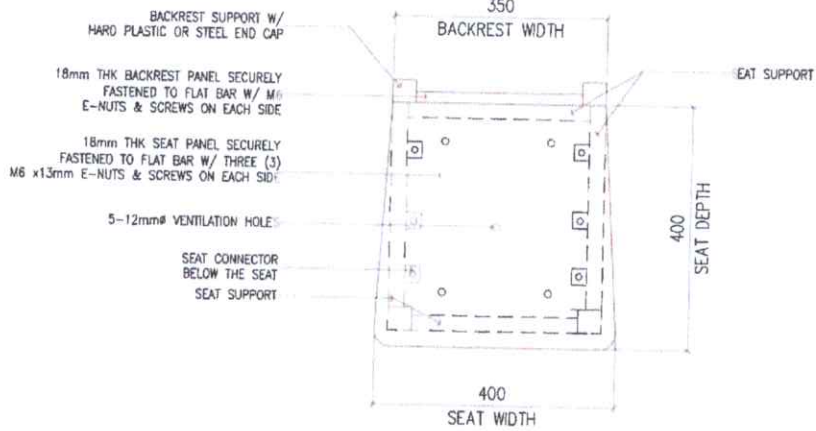

1 PLAN
2 SCALE 1 : 50 M

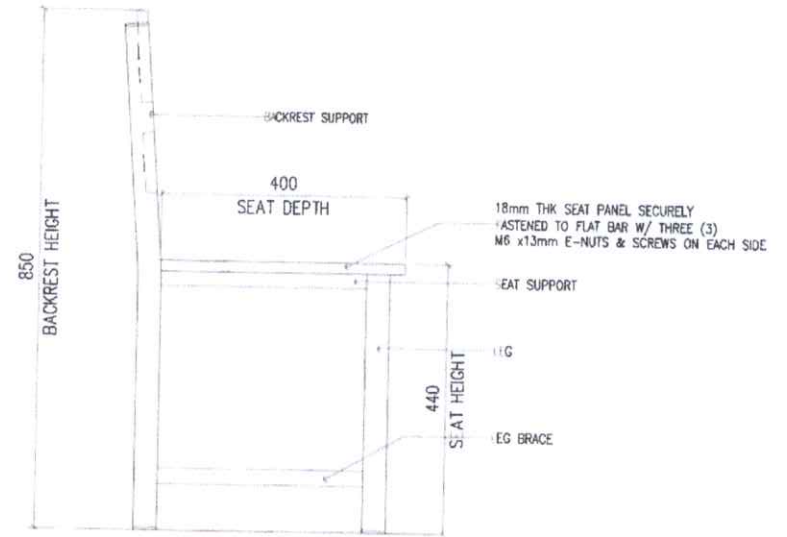

3 LEFT-SIDE ELEVATION
2 SCALE 1 : 50 M

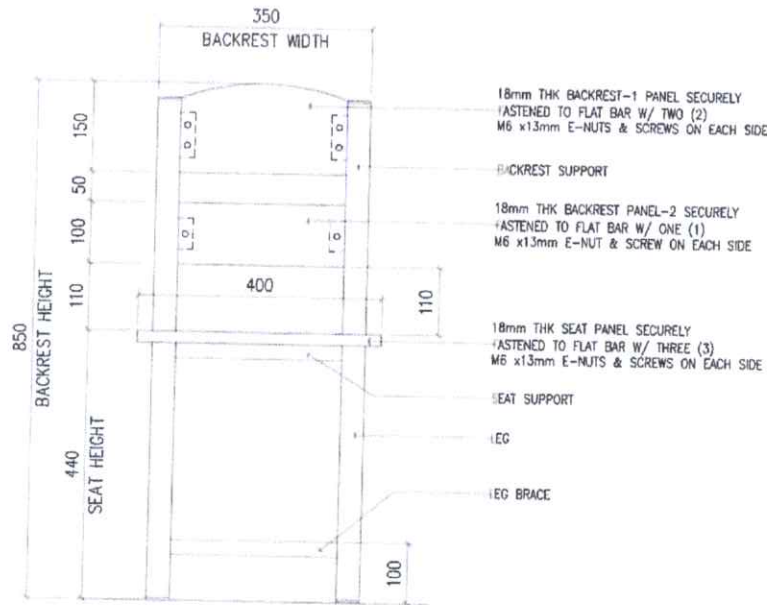

2 FRONT ELEVATION
2 SCALE 1 : 50 M

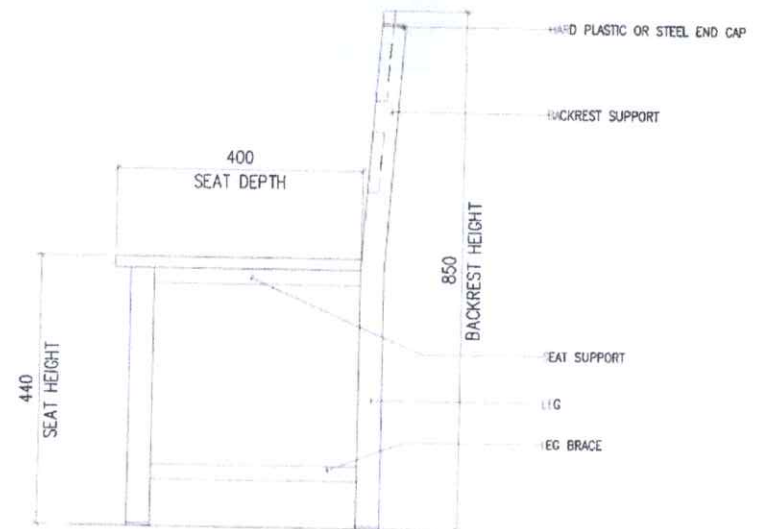

4 RIGHT-SIDE ELEVATION
2 SCALE 1 : 50 M

NOTES:
WOOD GLUE SHALL BE APPLIED BEFORE INSERTING E-NUT INTO THE PLYWOOD
CORNERS OF BACKREST & SEAT PANELS MUST BE ROUNDED

| | | | | | | | |
|---|--|--|---|--|---|--|----------------------------------|
| <p>REPUBLIC OF THE PHILIPPINES DEPARTMENT OF EDUCATION EDUCATION FACILITIES DIVISION HERALDO AVENUE, PASIG CITY</p> | <p>DESIGNED BY:</p> <p>JET RAYMOND G. ALABASTO ARCHITECT</p> | <p>RECOMMENDING APPROVAL:</p> <p>ENGR. ANABELLE B. BARRERA CHIEF - EDUCATION FACILITIES DIVISION</p> | <p>APPROVED BY:</p> <p>EPIMACO V. DINSING Undersecretary for School Infrastructure and Facilities</p> | <p>CONCURRED BY:</p> <p>GINA O. ONONG Undersecretary for Curriculum and Teaching</p> | <p>PROJECT TITLE:</p> <p>TEACHER'S CHAIR (WOOD & STEEL)</p> | <p>SHEET CONTENTS:</p> <p>PLANS & ELEVATIONS - TEACHER'S CHAIR</p> | <p>SHEET NO.:</p> <p>2 3</p> |
|---|--|--|---|--|---|--|----------------------------------|

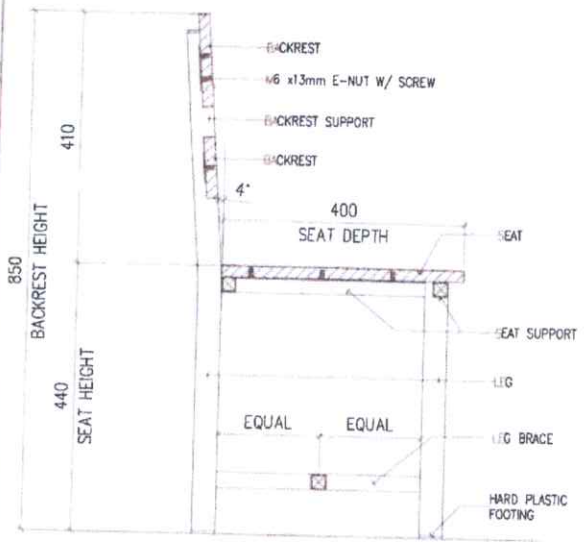

1 CROSS SECTION
3 SCALE 1 : 50 M

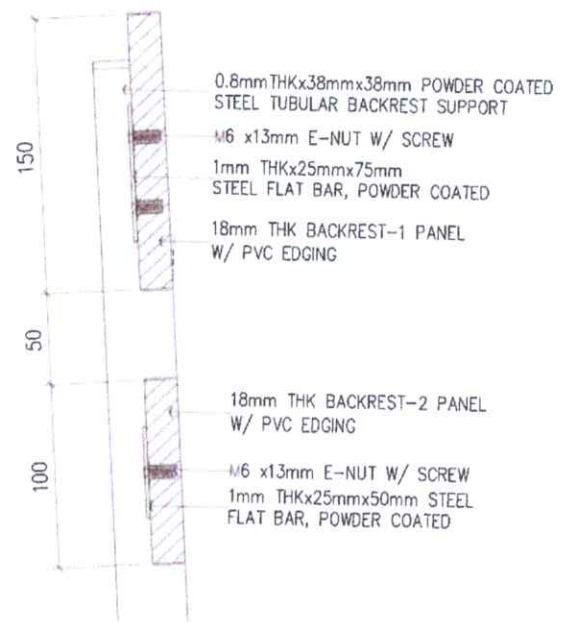

3 DETAIL - 1
3 SCALE 1 : 50 M

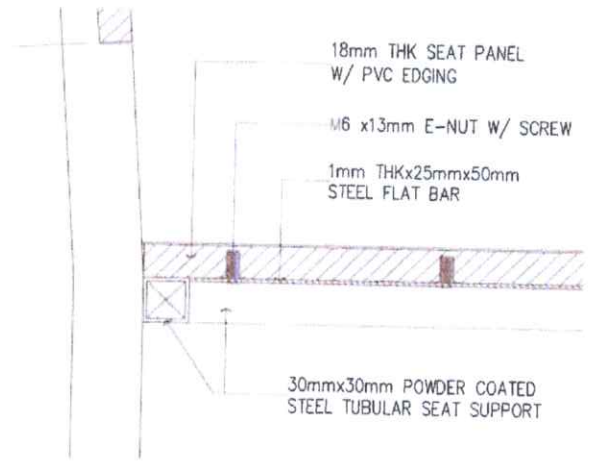

4 DETAIL - 2
3 SCALE 1 : 50 M

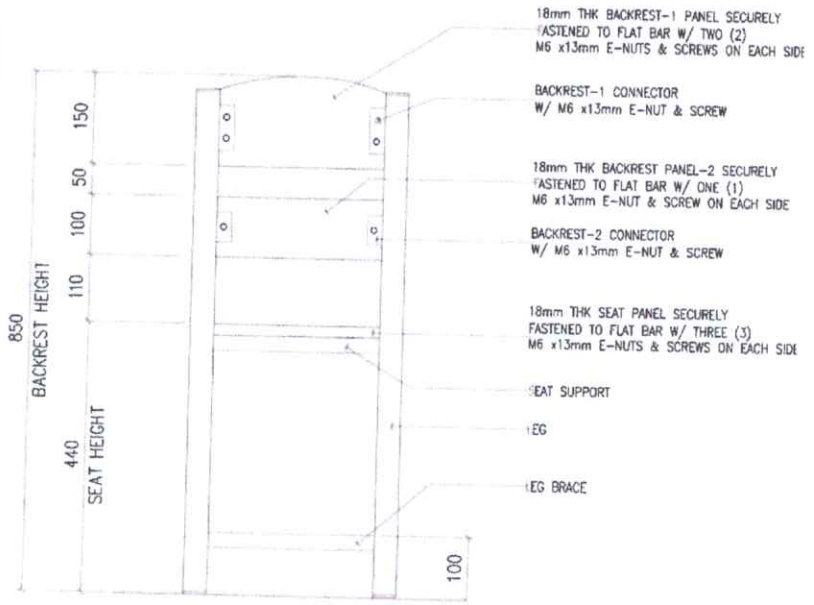

2 REAR ELEVATION
3 SCALE 50 M

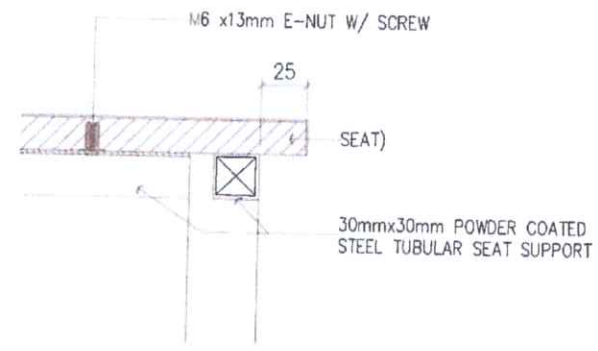

5 DETAIL - 3
3 SCALE 1 : 50 M

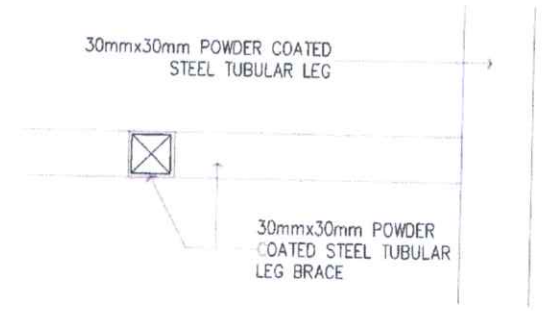

6 DETAIL - 4
3 SCALE 1 : 50 M

NOTES:
WOOD GLUE SHALL BE APPLIED BEFORE INSERTING E-NUT INTO THE PLYWOOD
CORNERS OF BACKREST & SEAT PANELS MUST BE ROUNDED

| | | | | | | | |
|--|--|--|---|--|---|--|---|
| REPUBLIC OF THE PHILIPPINES DepEd DEPARTMENT OF EDUCATION EDUCATION FACILITIES DIVISION RESEARCH, PLANNING & DESIGN | DRAWN BY: RAYMOND G. ALABASO ARCHITECT | RECOMMENDING APPROVAL: ENGR. ANNABELLE CHIEF - EDUCATION FACILITIES DIVISION | APPROVED BY: IMACULADA TENSING II Undersecretary for School Infrastructure and Facilities | CONCURRED BY: GINA O. GIRON Undersecretary for Curriculum and Teaching | PROJECT TITLE: TEACHER'S CHAIR (WOOD & STEEL) | SHEET COMMENTS: CROSS SECTION REAR ELEVATION SPOT DETAILS | SHEET NO. <div style="border: 1px solid black; border-radius: 50%; width: 30px; height: 30px; display: flex; align-items: center; justify-content: center;"> 3 </div> |
| | | | | | | | <div style="border: 1px solid black; border-radius: 50%; width: 30px; height: 30px; display: flex; align-items: center; justify-content: center;"> 3 </div> |